

Reliability forecasting models for electrical distribution systems considering component failures and planned outages

Kaigui Xie^{a,*}, Hua Zhang^a, Chanan Singh^b

^aState Key Laboratory of Power Transmission Equipment and System Security at Chongqing University, Chongqing 400030, PR China

^bDepartment of Electrical and Computer Engineering, Texas A&M University, College Station, TX 77843, USA

ARTICLE INFO

Article history:

Received 8 October 2014

Received in revised form 26 November 2015

Accepted 6 January 2016

Keywords:

Reliability forecasting

Electrical Distribution Systems (EDS)

Influencing factors

EDS component failures

Planned outages

Artificial neural networks

ABSTRACT

Many utilities in developing countries are investing in installation and renewing of Electrical Distribution System (EDS) components, such as overhead lines, cables and switching devices, to improve the EDS reliability and meet the rapid increase of load demand. In the beginning stage of investment, it is very difficult to evaluate the EDS reliability by using traditional methods due to EDS topology not being fully determined. This paper presents a comprehensive model for forecasting EDS reliability, which is built separately into two parts, i.e. the models for EDS failures and planned outages. Firstly, a three-layer Artificial Neural Network (ANN) model is proposed to forecast the EDS reliability considering EDS failures. Each neuron in the ANN input layer represents a key influencing factor of EDS failures, which are recognized by Gray Relational Analysis (GRA) method. The proposed ANN is trained using historical reliability data of an EDS. In addition, a planned outage reliability model is also built according to the magnitude of investment and type of planned outage. The priorities of improvement measures can also be obtained using the GRA to improve the EDS reliability. Case studies of practical EDSs illustrate the efficiency and applicability of the proposed techniques.

© 2016 Elsevier Ltd. All rights reserved.

Introduction

Forecasting technique is widely used in many research fields, such as load forecasting, temperature forecasting and stock market forecasting. Reliability forecasting of a power system, such as an Electrical Distribution System (EDS), is a statement about the system reliability performance that will be realized in the future based on current information.

EDS is an important link between power system supply and the distribution customers. EDS reliability forecasting techniques can be used to directly evaluate the reliability performance of an EDS in the future, analyze the reliability performance trend of an EDS, recognize the weak parts of an EDS, propose reliability improvement suggestions to design schemes, and address reliability price and unreliability cost contributions in an electricity market [1,2]. In other words, reliability forecasting techniques are considerably helpful in the processes of EDS design, planning and operation.

Currently, there exists considerable research on non-power-system reliability forecasting techniques. Ref. [3] proposed a soft-

ware reliability forecasting model using support vector regression, which was solved by a combination of genetic algorithm and simulated annealing algorithm. Ref. [4] proposed a real-time reliability forecasting technique for dynamic systems based on an online failure forecasting method. Ref. [5] proposed a reliability forecasting model for semiconductors using a combinatorial technique using fuzzy logic and component failure modes. Compared with other forecasting methods, Ref. [1] discussed the effectiveness of support vector machine in reliability forecasting for generating units. Ref. [6] proposed several pattern recognition algorithms and analyzed their practicability in component reliability forecasting. Ref. [7] used a technique called Group Method of Data Handling (GMDH) to forecast the reliability of flexible manufacturing systems.

Unfortunately, there has not been work on reliability forecasting of EDS. Ref. [8] proposed a forecasting method of EDS reliability indices by using logistic regression and dynamic regression models. Ref. [9] proposed a method for forecasting the reliability parameters, such as failure rate, of overhead distribution lines using radial-basis-function Artificial Neural Network (ANN), which was built by using data fitting techniques. Ref. [10] proposed a reliability forecasting method for EDS feeders using fuzzy set theory. It can be seen from the above discussion that time series methods, ANN and similar methods were used to forecast the reliability

* Corresponding author at: School of Electrical Engineering, Chongqing University, Chongqing 400044, PR China. Tel./fax: +86 23 65112729.

E-mail address: kaiguixie@vip.163.com (K. Xie).

performance for a component or an EDS based on the collected reliability information.

There is one key assumption implicit in the methods described, i.e. the component or EDS system reliability performance parameters have steady values. The behavior of component failures is typically a random process, which always results in the difficulty of establishing an accurate model for the component reliability parameters, such as failure rate. More importantly, many measures were used in EDS in these cases, such as replacing feeders and installation of switching devices and tie lines, which resulted in changes in the EDS system performance. Therefore, the above methods are unsuitable to forecast the changing reliability performance of an EDS. In addition, these methods lack inclusion of the effect analysis of key influencing factors on the EDS reliability, such as the number of tie lines, the average length of feeder sections and the ratio of insulated feeders to total feeders.

Although there are many factors influencing the EDS reliability performance based on the above analysis, there is relatively little research on the model of EDS reliability forecasting considering influencing factors. It is, therefore, important to propose an EDS reliability forecasting technique considering all key influencing factors.

This paper proposes an ANN model for forecasting the system reliability considering EDS component failures by exploring the relationship between the key influencing factors and the system reliability. It should be noted that the proposed method is mainly used in the following cases: (1) the EDS reliability performance may be change due to component installations and the change of EDS structure; (2) the network structure is not still fully determined and even parts of planning scheme need a little adjustment after taking improvement measures. In the developing countries, the EDS engineers always face these situations.

In the foregoing situations, on one hand, the EDS reliability evaluation cannot be conducted due to uncertainty of component reliability parameters and the structure of an EDS; on the other hand, directly evaluating the reliability performance of an EDS is a time-consuming process for an EDS with a large number of feeders. Therefore the reliability forecasting methods may provide a suitable tool to deal with these issues and situations.

Influencing factors of EDS component failures

EDS reliability indices

Total Customer Outage Hours (TCOH) is defined as the sum of products of the number of customers at each load point and its annual outage time. Total Customer Outages (TCO) is defined as the sum of products of the number of customers at each load point and its annual outages.

$$TCOH = \sum_{i \in R} U_i N_i \quad (1)$$

$$TCO = \sum_{i \in R} \lambda_i N_i \quad (2)$$

where U_i , λ_i and N_i are the annual outage time, outages and the number of customers at load point i , respectively; R the set of load points of an EDS.

There are many common EDS reliability indices being widely used in practical EDSs [11], including SAIDI (System Average Interruption Duration Index), SAIFI (System Average Interruption Frequency Index), ASAI (Average Service Availability Index) and ASUI (Average Service Unavailability Index).

$$SAIDI = \frac{TCOH}{\sum_{i \in R} N_i} \quad (3)$$

$$SAIFI = \frac{TCO}{\sum_{i \in R} N_i} \quad (4)$$

$$ASAI = 1 - \frac{TCOH}{8760 \sum_{i \in R} N_i} \quad (5)$$

$$ASUI = 1 - ASAI \quad (6)$$

It can be seen from (3)–(6) that the key step in the reliability forecasting and evaluation of an EDS is the calculation or forecasting of TCOH and TCO.

Both component failures and planned outages contribute to the unreliability of an EDS. Therefore, TCOH can be divided into two parts, i.e. TCOH-F (Total Customer Outage Hours due to component failures) and TCOH-P (Total Customer Outage Hours due to planned outages). Similarly, other indices, such as TCO-F, TCO-P, SAIDI-F and SAIDI-P, can be defined. For simplicity, TCOH is used as an example to explain the proposed concepts and forecasting processes.

Influencing factors of EDS component failures

Many factors, such as management level of utility, technical level of EDS engineers, average reliability performance of each type of component, proportion of each type of components and EDS configuration, influence the EDS reliability performance considering component failures. The reliability management level of utility, technical level of EDS engineers and average reliability performance of each type of components are assumed to be unchanged. Therefore, this paper studies the influencing factors of EDS component failures from other aspects, which are as follows:

- (1) F_1 : Ratio of available tie lines (%), ratio of the number of feeders in an EDS, which can be transferred to other feeders, to the number of total feeders;
- (2) F_2 : Ratio of cables (%), ratio of the length of cable feeders in an EDS to the total length of feeders;
- (3) F_3 : Ratio of insulated feeders (%), ratio of the length of insulated feeders in an EDS to the total length of feeders;
- (4) F_4 : Average length of each section (km/section), the total length of all feeders divided by the number of total sections in an EDS;
- (5) F_5 : Average number of customers in each section (customers/section), the number of total customers divided by the number of total sections in an EDS;
- (6) F_6 : Average number of circuit breakers of each feeder (breakers/feeder), the number of total circuit breakers divided by the number of total feeders in an EDS;
- (7) F_7 : Average number of transformers at each feeder (transformers/feeder), the number of total distribution transformers divided by the number of total feeders in an EDS;
- (8) F_8 : Average capacity of transformers at each feeder (MVA/feeder), total capacity of distribution transformers divided by the number of total feeders in an EDS;
- (9) F_9 : Ratio of tie lines (%), ratio of the number of feeders with tie lines in an EDS, to the number of total feeders;
- (10) F_{10} : Average number of switching devices at each section (devices/section), the number of total switching devices, such as disconnect switches and sectionalizing switches, divided by the number of total sections in an EDS;
- (11) F_{11} : Average sections of each feeder (sections /feeder), the number of total sections divided by the number of feeders in an EDS;
- (12) F_{12} : Average load factor of feeders (%), average load factor (the load of a feeder divided by the capacity of feeder) of feeders in an EDS in a year.

It should be noted that many other reliability influencing factors in an EDS, such as ratio of overload feeders to the total feeders, ratio of feeders with distribution automation devices to the total feeders and ratio of overload transformers to the total transformers, were not described above due to the space limitation.

Gray Relational Analysis of influencing factors

Gray Relational Analysis (GRA) [12] can be applied to analyzing the complicated relationship among multi variables. GRA can, therefore, be used to determine the degree of impact of different factors on the EDS reliability and further recognize the key reliability influencing factors, which is helpful in building an ANN forecasting model of EDS reliability considering failures.

The key step of GRA is to calculate Gray Relational Degree (GRD) between the original series and reference series. GRD calculation of TCOH-F is used as an example to explain the main steps [13].

Step 1: Standardize original series [14].

Assume that $F_i = (f_{i1}, f_{i2}, \dots, f_{ij}, \dots, f_{iN})$ is the i th ($i = 1, 2, \dots, M$) influencing factor of TCOH-F, i.e. the i th original series. N is the number of collected samples, and M is the total number of influencing factors.

Based on the original series, a standardized series $X_i = (x_{i1}, x_{i2}, \dots, x_{ij}, \dots, x_{iN})$ is given by

$$x_{ij} = \frac{f_{ij} - \min_j f_{ij}}{\max_j f_{ij} - \min_j f_{ij}} \quad (7)$$

Step 2: Standardize reference series.

The series of EDS reliability performance is chosen as the reference series, designated as $I_0 = (I_{01}, I_{02}, \dots, I_{0j}, \dots, I_{0N})$. Generally, the j th element I_{0j} of I_0 is the reliability index of the j th EDS, such as ASAI. Similarly, a standardized series $X_0 = (x_{01}, x_{02}, \dots, x_{0j}, \dots, x_{0N})$ of I_0 can also be obtained using (7).

Step 3: Calculate Gray relational coefficient (GRC).

GRC is used to determine the degree of closeness between x_{ij} and x_{0j} , which is given by

$$\gamma(x_{0j}, x_{ij}) = \frac{\Delta_{\min} + \xi \Delta_{\max}}{\Delta_{ij} + \xi \Delta_{\max}} \quad (8)$$

where $\gamma(x_{0j}, x_{ij})$ is the GRC between x_{ij} and x_{0j} ; ξ the resolution factor and $\xi \in [0, 1]$. Generally, ξ is 0.5.

$$\Delta_{ij} = |x_{0j} - x_{ij}|$$

$$\Delta_{\min} = \min_{ij} \Delta_{ij}$$

$$\Delta_{\max} = \max_{ij} \Delta_{ij}$$

Step 4: Calculate GRD.

GRD of original series X_i and reference series X_0 can be calculated by [15]:

$$r_{0i} = \frac{1}{n} \sum_{j=1}^n \gamma(x_{0j}, x_{ij}) \quad (9)$$

Key influencing factors of EDS component failures

Based on the GRA principles, the larger the GRD between an influencing factor series and TCOH-F series is, the closer the corre-

lation between the influencing factor and TCOH-F index. Therefore, a pre-specified GRD threshold can be used to recognize the key factors having strong correlation with TCOH-F. In other words, if a GRD is larger than the pre-specified one, then this factor can be recognized as a key influence one.

It should be noted that the pre-specified GRD threshold has a significant effect on the result of key factors and then on forecasting results. Therefore, if a pre-specified threshold cannot reach expected forecasting accuracy, the pre-specified threshold should automatically be adjusted until satisfied results are obtained.

In addition, to avoid the redundancy of key influencing factors, the GRD between any two key influencing factors should also be evaluated. If two key factors have a high degree of correlation, which is larger than a pre-specified GRD, then only one factor can be recognized as a key influencing factor.

Fig. 1 shows the flowchart for the determination of key influencing factors of EDS component failures.

Forecasting model of EDS reliability considering component failures

Establishment of ANN model

ANN has been widely used in many science and engineering fields [16–24]. Especially, BP (Back Propagation) ANN is the most-widely used one [18]. A three-layer BPANN with enough neurons in the hidden layer can be used to approximate an arbitrary mapping with K dimension inputs and I dimension outputs.

Fig. 2 shows a three-layer ANN for forecasting EDS reliability considering component failures. The structure of ANN is as follows.

- (1) Input layer: In order to avoid redundant variables or neurons, the number of neurons in this layer is equal to the number of key influencing factors recognized by the method mentioned in Section 'Influencing factors of EDS component failures'.
- (2) Hidden layer: Generally, the more the hidden layer neurons are, the more accurate the result is but computational time is also more. A formula based on experience can be used to appropriately determine the number of hidden layer neurons, which has been widely used in many problems [19]:

$$L = \frac{(K+I)}{2} + \sqrt{N_s} \quad (10)$$

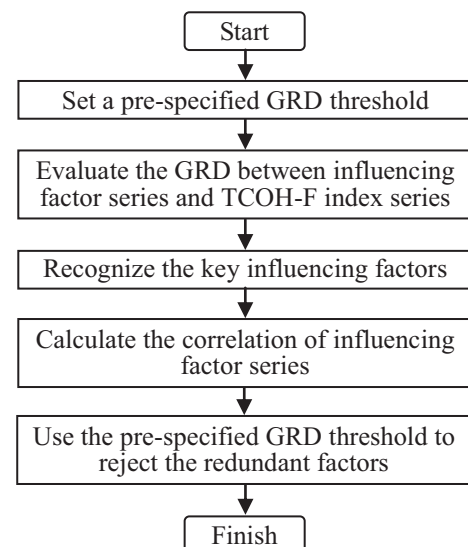

Fig. 1. Determination of key influencing factors of EDS component failures.

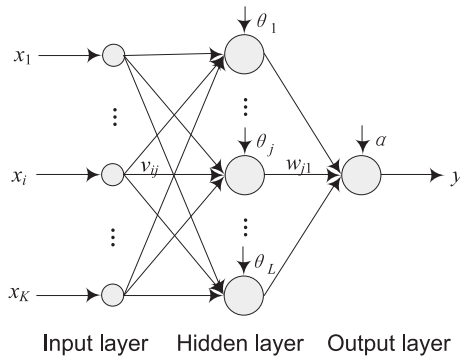

Fig. 2. Structure of a BPANN with three layers.

where K , L and I are the number of neurons in the input, hidden and output layers, respectively; N_s the number of training samples.

- (3) Output layer: The ANN output is the forecasted TCOH-F index, so the number of output layer neurons is 1, i.e. $I = 1$.

ANN training process

BP algorithm is widely used to train ANN. Using the least square technique, the training process of ANN can decrease the error sum of squares between the evaluated outputs and original outputs by constantly adjusting the ANN weights [23]. The error E between the original outputs and evaluated outputs is defined by

$$E = \frac{1}{2} \sum_{p=1}^{N_s} (d_p - y_p)^2 = \frac{1}{2} \sum_{p=1}^{N_s} [d_p - \psi(\text{net})]^2 \quad (11)$$

where

$$\text{net} = \sum_{j=1}^L w_{j1} \varphi \left(\sum_{i=1}^K v_{ij} x_i + \theta_j \right) + \alpha \quad (12)$$

where d_p and y_p are the calculated output and original output of sample p , respectively; net the input of output layer neuron; x_i the input of neuron i in the input layer; w_{j1} the weight from the neuron j in the hidden layer to the neuron in output layer; v_{ij} the weight from the neuron i to the neuron j ; $\varphi(x)$ and $\psi(x)$ the functions of hidden and output layers, respectively; θ_j and α the thresholds of neuron j in the hidden layer and the neuron in the output layer, respectively.

The error E is a function of the thresholds and weights of ANN, so E can be decreased by adjustment of thresholds and weights using a Gradient Descent Algorithm, which is given by [24]:

$$\Delta \alpha = \eta \sum_{p=1}^{N_s} [d_p - \psi(\text{net})] \psi'(\text{net}) \quad (13)$$

$$\Delta w_{j1} = \Delta \alpha \varphi \left(\sum_{i=1}^K v_{ij} x_i + \theta_j \right) \quad (14)$$

$$\Delta \theta_j = \Delta \alpha w_{j1} \phi' \left(\sum_{i=1}^K v_{ij} x_i + \theta_j \right) \quad (15)$$

$$\Delta v_{ij} = \Delta \alpha x_i \quad (16)$$

where $\Delta \alpha$ and Δw_{j1} are the threshold and weight modifications in output layer, respectively; $\Delta \theta_j$ and Δv_{ij} are the threshold modification and weight modification in the hidden layer, respectively.

Determination of key influencing factors in the forecasting year

The basic concepts of reliability forecasting method considering EDS component failures are: (1) to apply the collected historical data to train an ANN so as to build a nonlinear mapping relationship between the EDS reliability considering failures and key influencing factors; (2) to forecast the EDS reliability using the trained ANN and input data which are the key influencing factors in the forecasting year. Therefore, it is necessary to determine the amounts of key influencing factors in the forecasting year before using the ANN.

The planning scheme of an EDS is a valuable reference to determine the amount of influencing factors in the forecasting year. For example, according to the investment and planning schemes of feeders in an EDS in 2014, the total sections and total length of all feeders in 2014 can be obtained. Therefore, the amount of average length of each section, i.e. F_4 , in 2014, can be obtained. Similarly, the other amounts of key factors in the forecasting year can also be obtained.

Forecasting TCOH-F

TCOH-F forecasting of an EDS in 2014 is used as an example to explain the forecasting model using the influencing factor series and TCOH-F series during the years 2004–2013. The TCOH-F forecasting algorithm is shown as follows.

- Step 1: Collect historical TCOH-F indices and data of influencing factors during the years 2004–2013, and build the original series and reference series;
- Step 2: Standardize the series using (7);
- Step 3: Recognize the key influencing factors of TCOH-F by GRA method in Section 'Influencing factors of EDS component failures';
- Step 4: Divide the standardized data into training set and test set. The training set includes the data during the years 2004–2012 and the test set includes the data in 2013;
- Step 5: Determine the structure of BPANN;
- Step 6: Train the ANN using (11)–(16);
- Step 7: Test ANN forecasting model using data in 2013;
- Step 8: Determine the amounts of key influencing factors in 2014;
- Step 9: Forecast the TCOH-F index in 2014 using the ANN model.

Forecasting EDS reliability considering planned outages

Section 'Forecasting model of EDS reliability considering component failures' proposed a TCOH-F forecasting method considering EDS component failures. As commonly known, reliability performance of an EDS is also influenced by planned outages. Generally, planned outages are mainly focused on the implementation of engineering projects, such as EDS component replacement, installation, maintenance and test, which can be notified to customers in advance by planning and operation departments.

Planned outages are closely related with annual engineering projects and investments. A forecasting algorithm for TCOH-P is proposed based on the relationship between the investment of different engineering projects and TCOH-P. The main procedure is as follows.

- Step 1: Classify the EDS projects into different types, such as distribution line project, switching device project and distribution transformer project, and obtain the statistical data about the investment and TCOH-P of each type in recent years;

- Step 2: Calculate average TCOH-P of a unit investment for each type of project, and designate as h_i ;
- Step 3: Obtain the investment M_i of each type of projects according to the annual investment list in the forecasting year;
- Step 4: Forecasting TCOH-P:

$$TCOH-P = \sum_{i=1}^{N_{ty}} h_i M_i \tag{17}$$

where N_{ty} is the number of project type.

EDS reliability forecasting considering component failures and planned outages

Based on the forecasted TCOH-F considering EDS component failures and TCOH-P considering planned outages, total TCOH can be given by

$$TCOH = TCOH-F + TCOH-P \tag{18}$$

TCOH is also used as an example to explain the procedures of EDS reliability forecasting.

- Step 1: Build a forecasting model considering EDS component failures, which was proposed in Section ‘Forecasting model of EDS reliability considering component failures’;
- Step 2: Determine the magnitudes of key influencing factors of TCOH-F in forecasting year;
- Step 3: Forecast the TCOH-F in the forecasting year;
- Step 4: Build a forecasting model considering EDS planned outages, which was proposed in Section ‘Forecasting EDS reliability considering planned outages’, and forecast TCOH-P in the forecasting year;
- Step 5: Obtain TCOH using (18), and forecast EDS system indices using (3)–(6).

Based on (3)–(6) and (18), SAIDI, ASAI and other EDS system reliability indices can also be forecasted.

If the collected historical data are not enough, the accuracy of EDS reliability forecasting model can hardly satisfy the requirement. In order to obtain an acceptable accuracy, a large-scale EDS can be divided into several parts, which have similar levels in economic development, component reliability performance

and management. Then each part can be looked on as an EDS to establish a reliability forecasting model.

When the influencing factors in a given period of time, such as one day or one year, are known and used in the proposed techniques the reliability of EDS for this time scale can be forecasted.

Case studies

The 10 kV EDSs in a Power Supply Bureau (PSB) with a peak load more than 10,000 MW are used as examples to illustrate the validity and the effectiveness of the proposed method for forecasting the EDS reliability.

The PSB had 33 EDSs in 2013. Table 1 shows the statistical data of 33 EDSs. I_0 is the collected historical TCOH-F series, and F_i ($i = 1, 2, \dots, 12$) is the series of the i th influencing factors defined in Section ‘Influencing factors of EDS component failures’.

Recognizing key influencing factors of EDS component failures

Table 2 shows the GRD between each influencing factor series F_i and I_0 of TCOH-F series. Table 3 shows the mean absolute percentage errors (MAPE) of forecasted SAIDI indices with different pre-specified GRD thresholds using the proposed model. It can be seen from Table 3 that the pre-specified GRD threshold of 0.75 can reach a minimum MAPE.

It can also be seen from Table 2 that there are 8 factors with the GRD more than 0.75, which are influencing factors $F_1, F_2, F_3, F_5, F_9, F_{10}, F_{11}$ and F_{12} . These 8 factors are the candidates of key influencing factors.

Table 4 shows the GRD between any two influencing factors. It can be seen from Table 4 that the GRDs between factors F_2 and F_3 and F_{10} and F_{11} are more than 0.75, which indicates that there are strong correlations between those factors. This is consistent with the engineering experience analysis. Therefore, the redundancy factors F_2 and F_{10} should be deleted due to $r_{03} > r_{02}$ and $r_{011} > r_{010}$.

Table 3
MAPE of forecasted SAIDI indices with different GRD thresholds.

Pre-specified GRD threshold	0.50	0.55	0.60	0.65	0.70	0.75	0.8	0.85
MAPE (%)	11.45	11.45	9.68	9.68	9.68	3.09	6.73	10.11

Table 1
Statistical data of 10 kV EDSs.

EDS no.	I_0	F_1	F_2	F_3	F_4	F_5	F_6	F_7	F_8	F_9	F_{10}	F_{11}	F_{12}
1	3.11	26.79	56.12	57.57	4.29	11.24	0.37	15.98	9.57	0.92	1.05	1.07	73.33
2	1.66	48.94	87.25	89.94	1.28	4.36	0.3	9.28	6.15	1.57	1.76	1.80	39.41
3	1.58	50.71	73.06	73.35	1.76	4.65	0.33	8.31	5.50	2.06	2.07	2.12	48.41
4	0.91	95.84	97.18	97.3	1.81	5.02	1.08	5.74	3.22	2.58	3.62	3.63	33.67
5	2.01	44.93	71.36	71.36	3.42	10.03	0.64	12.03	7.97	1.09	1.56	1.59	51.26
6	1.55	62.44	62.49	69.51	3.67	7.54	1.09	11.43	9.56	1.82	1.82	1.86	52.51
7	1.97	48.32	58.02	59.63	3.83	9.61	1	15.86	10.50	0.98	1.72	1.75	56.83
8	2.20	40.56	81.13	81.13	2.87	6.99	0.59	8.21	5.44	1.29	1.29	1.32	42.96
...
32	1.73	46.08	76.63	79.72	1.27	3.71	0.3	11.05	7.32	1.62	1.81	1.85	41.13
33	1.88	39.88	75.27	76.28	1.29	4.18	0.29	10.60	7.02	1.43	1.67	1.70	43.68

Table 2
GRD between each influencing factor and I_0 .

Factor no.	r_{01}	r_{02}	r_{03}	r_{04}	r_{05}	r_{06}	r_{07}	r_{08}	r_{09}	r_{010}	r_{011}	r_{012}
GRD	0.8864	0.7641	0.7883	0.7245	0.7687	0.4852	0.6806	0.5864	0.8322	0.8495	0.8640	0.7951

Table 4
GRD between any two influencing factors.

	F_1	F_2	F_3	F_5	F_9	F_{10}	F_{11}	F_{12}
F_1	1.00	0.43	0.39	0.46	0.61	0.51	0.50	0.46
F_2	–	1.00	0.86	0.38	0.52	0.49	0.47	0.52
F_3	–	–	1.00	0.43	0.46	0.46	0.49	0.44
F_5	–	–	–	1.00	0.52	0.49	0.43	0.63
F_9	–	–	–	–	1.00	0.48	0.46	0.52
F_{10}	–	–	–	–	–	1.00	0.88	0.43
F_{11}	–	–	–	–	–	–	1.00	0.42
F_{12}	–	–	–	–	–	–	–	1.00

Table 5
Amounts of key influencing factors in 33 EDSs in 2013.

EDS no.	Key influencing factors					
	F_1 (%)	F_3 (%)	F_5	F_9	F_{11}	F_{12} (%)
1	33.30	58.80	10.68	1.05	1.86	54.83
2	50.84	95.33	4.33	1.62	2.32	37.95
3	50.73	76.45	4.83	2.03	2.89	48.71
4	98.60	97.04	5.08	2.57	3.66	40.49
5	57.90	82.87	10.45	1.58	1.83	53.78
6	60.55	67.58	7.57	1.95	1.43	62.18
7	52.42	61.93	9.68	1.06	1.27	47.81
8	62.59	90.86	6.99	1.29	2.36	46.68
...
32	51.19	79.39	3.80	1.64	3.52	39.12
33	40.97	77.84	4.23	1.44	3.40	37.48

Based on the above analysis, the input variables of ANN model, which are recognized as the key influencing factors of the EDS component failures, are F_1 , F_3 , F_5 , F_9 , F_{11} and F_{12} . In other words, F_2 and F_{10} were removed from the candidates of key influencing factors, and the number of the key influencing factors was changed to 6 from the original number of 8.

Forecasting the EDS reliability indices

A three-layer ANN was built to forecast the EDS reliability, whose number of neurons in input, hidden and output layers are 6, 9 and 1, respectively. Let the pre-specified convergence accuracy of ANN model be 0.0005.

The collected historical 10 kV EDSs data during the years 2004–2012 were used to train the ANN model. The training process was stopped with 45 generations using the accuracy of 0.00048. Table 5 shows the amounts of key influencing factors in 2013 based on the planning schemes. Tables 6 and 7 show the forecasting SAIDI indices in 2013 and 2014, respectively.

Table 6
Forecasted SAIDI indices of 33 EDSs in 2013.

EDS no.	SAIDI-F*			SAIDI-P*			SAIDI		
	Forecasted	Original	Error (%)	Forecasted	Original	Error (%)	Forecasted	Original	Error (%)
1	2.74	2.85	–3.71	6.94	6.75	2.93	9.77	9.60	1.81
2	1.92	1.89	1.66	5.93	6.24	–5.02	7.85	8.13	–3.48
3	1.60	1.49	7.15	3.16	3.36	–5.85	4.64	4.85	–4.33
4	0.83	0.77	7.40	0.59	0.64	–8.32	1.42	1.41	0.48
5	1.83	1.87	–2.24	4.27	4.38	–2.63	6.09	6.25	–2.57
6	1.59	1.62	–1.87	3.51	3.62	–3.08	5.08	5.24	–2.96
7	1.51	1.41	7.06	1.27	1.34	–5.42	2.68	2.75	–2.44
8	1.82	1.84	–0.95	1.88	1.96	–4.16	3.70	3.80	–2.67
...
32	1.34	1.25	6.83	2.51	2.35	6.85	3.85	3.60	6.84
33	1.61	1.52	6.05	3.67	3.84	–4.51	5.18	5.36	–3.28

Note: SAIDI-F and SAIDI-P are the SAIDI indices using NCFI-F and NCFI-P in (3), respectively.

Table 7
Forecasted SAIDI and ASAI indices of 33 EDSs in 2014.

EDS no.	SAIDI-F	SAIDI-P	SAIDI	ASAI (%)
1	2.37	2.04	4.41	99.95
2	1.83	3.87	5.70	99.93
3	0.98	3.46	4.44	99.95
4	0.69	0.90	1.59	99.98
5	1.65	2.99	4.64	99.95
6	1.32	5.32	6.64	99.92
7	1.58	4.22	5.80	99.93
8	1.78	4.28	6.06	99.93
...
32	0.95	2.55	3.50	99.96
33	1.21	1.85	3.06	99.97

It can be seen from Table 6 that the maximum absolute error of the proposed forecasting model is 6.84% and mean absolute error is 3.09%, which indicate that the proposed model is efficient and applicable of forecasting EDS reliability.

In addition, the proposed method was also applied to forecasting EDS system reliability in many power supply bureaus in Guangdong, Hainan and Henan provinces, China. All the mean absolute errors are around 3%.

Conclusions

This paper proposes a comprehensive technique for forecasting EDS reliability, which has two parts, i.e. the models for EDS component failures and planned outages. A three-layer ANN model was built to forecast the system reliability considering EDS component failures. Based on the values of key factors in the next years, the reliability indices of EDS can be forecasted by the trained ANN. In addition, this paper also proposed a planned outage reliability model considering the amount of investments and type of planned outages. The proposed techniques are actually general methods for EDS reliability forecasting without any special assumptions or

requirements associated with the time scales, and can be used to forecast the short-term and long term reliability of EDSs.

The proposed method was used to forecast the reliability of actual 10 kV EDSs in China. The case studies indicate that the proposed method has a high enough forecasting accuracy to satisfy the requirements of engineering and management decisions.

This paper also proposes a method for identifying key influencing factors of component failures using the GRD between the EDS reliability series and the influencing factor series. The priorities of key influencing factors can be used to improve the EDS reliability with more benefits.

As commonly known, there are many factors influencing the system reliability of an EDS. Different EDSs have different key reliability influencing factors. In addition, the key influencing factors of an EDS also change with the time.

Acknowledgements

This work was supported in part by the National Natural Science Foundation of China (No. 51377178).

The authors are thankful to the engineers in power supply bureaus in Dongguan city, Hainan and Henan provinces, China, for providing the practical data.

References

- [1] Moura MC, Zio E, Lins ID, Drogue EL. Failure and reliability prediction by support vector machines regression of time series data. *Reliab Eng Syst Saf* 2011;96(11):1527–34.
- [2] Moura MC, Drogue EL. Mathematical formulation and numerical treatment based on transition frequency densities and quadrature methods for non-homogeneous semi-Markov processes. *Reliab Eng Syst Saf* 2009;94(2):342–9.
- [3] Jin C. Software reliability prediction based on support vector regression using a hybrid genetic algorithm and simulated annealing algorithm. *IET Software* 2011;5(4):398–405.
- [4] Xu Z, Ji Y, Zhou D. A new real-time reliability prediction method for dynamic systems based on on-line fault prediction. *IEEE Trans Reliab* 2009;58(3):523–38.
- [5] Bazu M. A combined fuzzy-logic & physics-of-failure approach to reliability prediction. *IEEE Trans Reliab* 1995;44(2):237–42.
- [6] Luchino AI. Informative parameters in individual quality estimation and reliability forecasting. *Int J Model Simul* 1990;10(2):75–82.
- [7] Yuandis P, Styblinski M, Smith D, Singh C. Reliability modeling of flexible manufacturing systems. *Microelectron Reliab* 1994;34(7):1203–20.
- [8] Li M, Su C, Shen C. Prediction of reliability and public safety from covered rates using time series modeling for distribution systems. *Eur Trans Electr Power* 2011;21(1):1128–38.
- [9] Cochenour G, Simon J, Das S, Pahwa A, Nag S. A pareto archive evolutionary strategy based radial basis function NN training algorithm for failure rate prediction in overhead feeders. In: Genetic and evolutionary computation conference, Washington, DC; June 2005.
- [10] Katithummarugs S, Apiwattananon A, Labchareonwong P. Reliability index prediction using fuzzy principle. In: 2010 Asia-pacific power and energy engineering conference (APPEEC 2010); March 2010.
- [11] Billinton R, Allan RN. Reliability evaluation of power systems. New York, London: Plenum Press; 1992. ISBN 978-1-4899-1862-8.
- [12] Morán J, Granada E, Miguez JL, Porteiro J. Use of gray relational analysis to assess and optimize small biomass boilers. *Fuel Process Technol* 2006;87(2):123–7.
- [13] Kuo Y, Yang T, Huang G. The use of gray relational analysis in solving multiple attribute decision-making problems. *Comput Ind Eng* 2008;55(1):80–93.
- [14] Hsia KH, Chen MY, Chang MC. Comments on data pre-processing for gray relational analysis. *J Gray Syst* 2004;7(1):15–20.
- [15] Jiang BC, Tasi S, Wang C. Machine vision-based gray relational theory applied to marking inspection. *IEEE Trans Semicond Manuf* 2002;15(4):531–9.
- [16] Shaban K, El-Hag A, Matveev A. A cascade of artificial NNs to predict transformers oil parameters. *IEEE Trans Dielectr Electr Insul* 2009;16(2):516–23.
- [17] Fang K, Mu D, Chen S, Wu B, Wu F. A prediction model based on artificial NN for surface temperature simulation of nickel-metal hydride battery during charging. *J Power Sources* 2012;208:378–82.
- [18] Rumelhart DE, Hinton GE, Williams RJ. Learning internal representation by error propagated. *Parallel Distrib Process* 1986;1(12):318–62. MIT Press, Cambridge, MA.
- [19] Kalogirou SA, Neocleous CE, Schizas CN. A comparative study of methods for estimating intercept factor of parabolic trough collectors. In: Proceedings of the international conference EANN'96 1996, London, UK. p. 5–8.
- [20] Kalogirou SA. Artificial NNs for predicting the local concentration ratio of parabolic trough collectors. In: Proceedings of the international conference EuroSun'96 1996, Freiburg, Germany. p. 470–475.
- [21] Kalogirou SA, Neocleous CE, Schizas SN. Artificial NNs for the estimation of the performance of a parabolic trough collector steam generation system. In: Proceedings of the international conference EANN'97 1997, Stockholm, Sweden. p. 227–32.
- [22] Kalogirou SA, Neocleous CC, Schizas CN. Artificial NNs for modelling the starting-up of a solar steam generator. *Appl Energy* 1998;60:89–100.
- [23] Fung CC, Wong KW, Eren H. Modular artificial NN for prediction of petrophysical properties from well log data. *IEEE Trans Instrum Meas* 1997;46(6):1295–9.
- [24] Kalogirou SA, Bojic M. Artificial NNs for the prediction of the energy consumption of a passive solar building. *Energy* 2000;25(5):479–91.