

Islanding detection method based on a new approach to voltage phase angle of constant power inverters

Hajir Pourbabak ✉, Ahad Kazemi

Department of Electrical Engineering, The Center of Excellence for Power Systems Automation and Operation, Iran University of Science and Technology, Tehran, Iran

✉ E-mail: hajir_pourbabak@elec.iust.ac.ir

ISSN 1751-8687

Received on 24th June 2015

Revised on 24th October 2015

Accepted on 23rd November 2015

doi: 10.1049/iet-gtd.2015.0776

www.ietdl.org

Abstract: This study presents a new islanding detection approach using the notion of active methods. A difference between the instantaneous and nominal voltage phase angle (VPA) of a distributed generation (DG) is applied to inverter-based interface control. After the islanding phenomenon, currents i_d and i_q will be changed by adding the variation of the point of common coupling VPA to input of d - q transformation block of currents. This subsequently causes the voltage and frequency deviations using for detecting island. Active islanding detection techniques usually leave adverse effects on power quality. The considerable advantages of the proposed method include insignificant negative effects on the power quality in the normal operation of the power system. The performance of the proposed islanding detection method is evaluated by some common test presented in UL1741; in addition, the results of some tests are presented for multiple DGs that show the proposed method does not cause significant interference between two DGs in the operational mode. Analogous to the case of a single DG, the island was also detected well in the case of multiple DGs.

Nomenclature

DG	distributed generation
EPS	electric power system
PCC	point of common coupling
VPA	voltage phase angle
f	frequency
Q_f	load quality factor
U	line-to-line voltage
i_d, i_q	d -axis and q -axis currents of inverter
u_d, v_q	d -axis and q -axis voltages of PCC
P_{ref} and Q_{ref}	reference values
ΔP and ΔQ	power mismatches

1 Introduction

The distributed generation (DG) can be defined as electric generation facilities connected to an area of an electric power system (EPS) through point of common coupling (PCC), which is located nearby local loads [1]. In recent years, the penetration of DGs in power systems is increasing [2, 3].

The connections of DGs to utility system have some protection issues such as islanding. The unintentional islanding refers to the condition that one or more DGs and some loads are disconnected from the rest of main power system while the loads are supplied by DGs in the isolated part of the power [4, 5]. The islanding situation imposes some considerable problems into power systems such as power quality problems (frequency and voltage deviations), safety hazards to network personnel, overload condition, adverse effects on system's protection and reconnecting problems [6–8]. Thus, island must be detected by islanding detection methods immediately.

Various methods are proposed for the islanding detection by researchers. Islanding detection methods could be categorised as communication and local detection methods. Moreover, local detection methods can be considered as passive and active methods [7, 9].

The passive methods detect island by monitoring the changes of parameters such as frequency deviation or voltage variation at the PCC. Not only are they both simple and low-priced to implement, but also they have no considerable adverse effects on the power system and DGs operation. If the power mismatch between loads and DG is small, the deviation of parameters will not go beyond the threshold. Therefore, the passive methods cannot detect island condition in a reasonable time because they have a large non-detection zone. Thus, the only deviation of system parameters cannot be enough criteria for islanding detection [10–12]. The over or under voltage and frequency protection, phase jump detection and rate of change of frequency and power are some of typical passive [13–15].

In active methods, a small disturbance is injected into the power system by DG through the PCC to create changes in the system parameters. In fact, in the grid-connected mode, the small disturbance cannot create considerable variations in the power system parameters such as voltage or frequency because the DG parameters are dictated by the power system. However, when an island is formed, the small disturbance can create an enough variation in the island parameters. Hence, active methods have a smaller non-detection zone compared with the passive methods [16, 17], but due to the disturbance injection, they have unfavourable impacts on the power quality. Active methods are usually applied to DGs more than other methods despite their disadvantages imposed on power quality. They do not need costly communication infrastructure and, also, their detection accuracy is better than that of passive methods [18]. Some of active methods that have been recently proposed are slip-mode frequency shift (SMS), Sandia frequency shift (SFS), negative-sequence current injection [19–21], robust anti-islanding algorithm [22] and voltage positive feedback for voltage source inverter [23–26].

This paper proposes a new active detection approach with insignificant negative impacts on the power quality. The implementation of this method does not require any considerable changes in structure of inverter and does not cause any problem for DG and the power system during load switching. In the proposed method, the difference between the DG instantaneous voltage phase angle (VPA) and the nominal VPA, which is constant, will be added to the input angle of abc -to- dqo transformation block [derived from phase-locked loop (PLL) block]. In the islanding

condition, the instantaneous VPA will change; thus, the error amplitude (difference) will be grown. In the grid-connected mode, the error value is insignificant because instantaneous VPA is close to the nominal VPA; therefore, this method will not negatively affect the system parameters. In fact, there are no significant adverse effects on the power quality during grid connected mode of power systems. Despite insignificant problems of power quality, the islanding detection time is reasonable in this method.

The rest of paper is structured as follows. Section 2 presents the power system model and DG control system. In Section 3, the intended method is described. Section 4 provides simulation proofs for evaluation.

2 System under study and control scheme

Fig. 1 shows a single line diagram of a test system, consisting of an inverter (DG), a load and the power system network. The DG is modelled as a constant power source that should approximately operate at the power factor of one when it works above 10% of its capacity to supply the power system and loads in its highest capacity [5, 27].

The loads used in islanding detection studies are usually modelled as three-phase RLC loads cause the serious difficulties in the islanding detection procedure [6, 28] because there are not important troubles in the islanding detection for constant power or non-linear loads. In the grid-connected mode, the utility power system provides load's demanded reactive power. Since DG operates close to the unity power factor, it cannot provide the demanded reactive power of load in the islanding condition. Consequently, the island frequency will be dictated by the load resonance frequency. If it is same as the system nominal frequency, the frequency will not change significantly. Based on UL1741 [29], the load resonance frequency is assumed to be near the system operational frequency [9] and the active power mismatch between RLC load and DG is small because a worst-case should be assumed in the islanding detection test. Based on [1], load parameters are calculated by the following equation

$$L = \frac{U^2}{2\pi f Q_f P}, \quad C = \frac{P Q_f}{2\pi f U^2}, \quad R = \frac{U^2}{P} \quad (1)$$

The DG control block diagram is shown in Fig. 2. The d -axis and q -axis currents of the inverter are controlled by a simple d - q synchronous reference frame. In the case of transforming to the d - q synchronous reference frame, the instantaneous active power will be represented by (2). If the q -axis is precisely in phase with the a -axis of voltage vector and the d -axis is in quadrature with that, u_d and u_q will be equal to zero and the magnitude of voltage, respectively [30, 31]. Thus, active and reactive powers are derived by the following equations

$$P = \frac{3}{2} (u_d i_d + u_q i_q) \quad (2)$$

$$P = \frac{3}{2} u_q i_q, \quad Q = -\frac{3}{2} u_d i_d \quad (3)$$

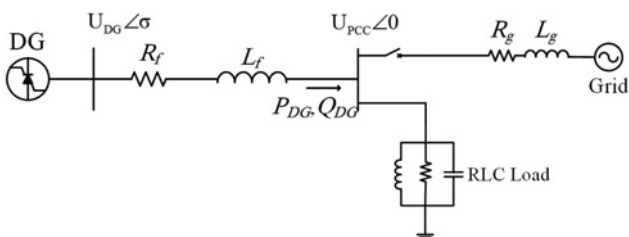

Fig. 1 System under study

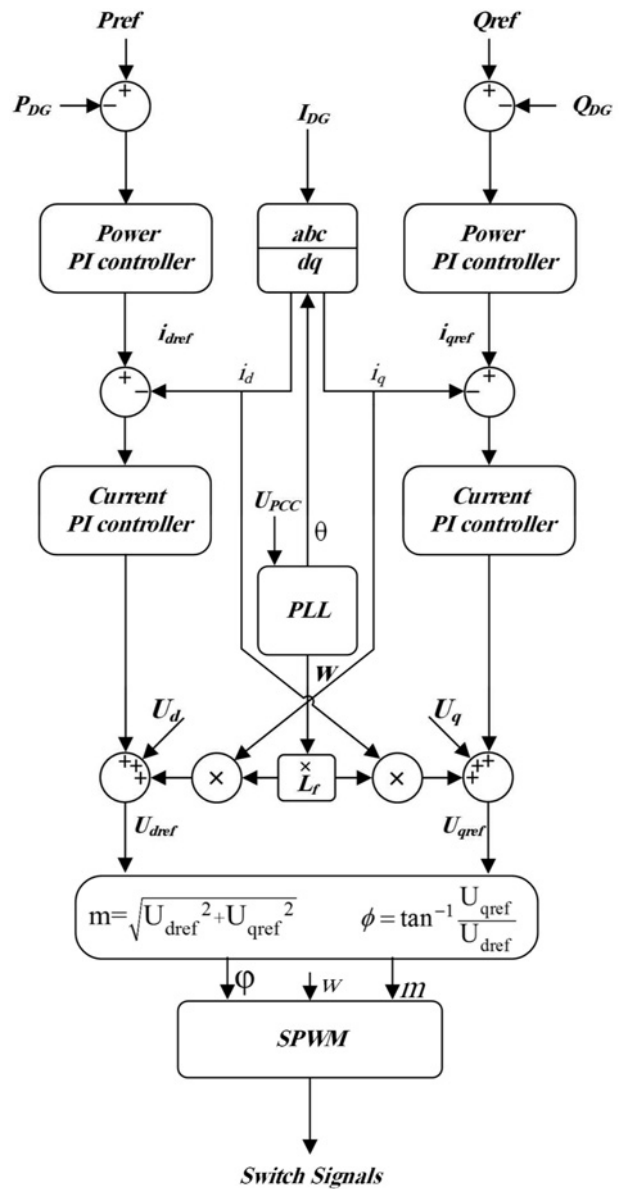

Fig. 2 DG controller scheme

As shown in (3), active and reactive powers can be controlled by i_q and i_d , respectively. The DG is a constant power source and the active and reactive powers of it will be controlled by the given reference powers of $(P_{ref} = 0.1 \text{ MW}$ and $Q_{ref} = 0 \text{ MW})$ [27]. Proportional–integral (PI) controllers of power regulation produce i_{dref} and i_{qref} . The error of current references and d - q current components will be detected by the current regulation PI controller to create the voltage references.

3 Proposed detection method

Equations (4) and (5) indicate the power balance at the PCC

$$P_{load} = P_{DG} + \Delta P \quad (4)$$

$$Q_{load} = Q_{DG} + \Delta Q \quad (5)$$

ΔP and ΔQ indicate powers exchanged between the utility power system and a possible island. In grid-connected mode, the power system dictates the value of voltage and frequency. However, when the island is formed, P_{load} and Q_{load} given by (6) and (7)

affect the value of voltage and frequency at the PCC

$$P_{load} = \frac{U_{PCC}^2}{R_{Load}} \quad (6)$$

$$Q_{load} = U_{PCC}^2 \left(\frac{1}{\omega L} - \omega c \right) \quad (7)$$

The frequency will not change enough to be suitable for islanding detection. This is mainly because of the fact that the resonance frequency of RLC load is equal to the system nominal frequency and the DG operates near unity power factor. Therefore, if the power mismatch (ΔP and ΔQ) is not considerable, the frequency and voltage deviation will not change sufficiently after islanding phenomenon.

Equations (8) and (9) show the active powers that flow from the DG toward PCC and the injected reactive power into the PCC. The phase angle of PCC voltage (i.e. U_{PCC}) is the reference during simulation process

$$P_{DG} = \frac{U_{DG} U_{PCC}}{X_f} \sin \sigma \quad (8)$$

$$Q_{DG} = \frac{U_{DG} U_{PCC}}{X_f} \cos \sigma - \frac{U_{PCC}^2}{X_f} \quad (9)$$

Equation (10) is obtained from (8) and (9). Q_{DG} is almost equal to zero because DGs operates at the power factor of one, in addition, P_{DG} can be replaced by P_{ref} . Thus, (10) can be written again as the following equation

$$\tan \sigma = \frac{P_{DG}}{Q_{DG} + (U_{PCC}^2 / X_f)} \quad (10)$$

$$\tan \sigma_n = \frac{X_f P_{ref}}{U_{PCC}^2} \quad (11)$$

The nominal VPA is calculated by (11) for every DG connected to the power system. When an island is formed, the inverter VPA (σ) will be changed because the power system cannot exchange the power with the island area. Due to the small power mismatch, this variation is very insignificant. In the proposed method, the difference between the instantaneous VPA (σ) and the nominal VPA of DG (σ_n) obtained from (11) will be added to the input angle of *abc-to-dqo* transformation block. Since the output power

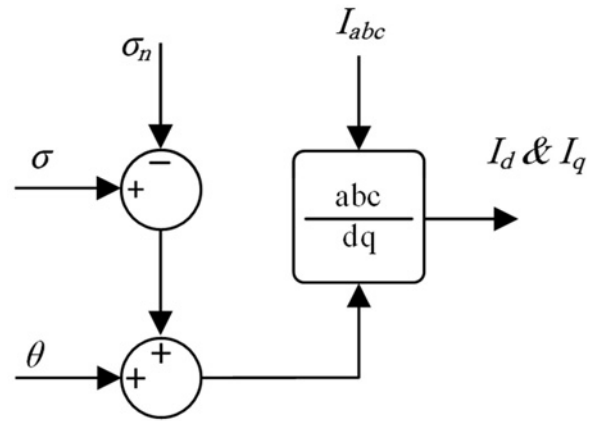

Fig. 3 Additional block of the proposed method

Table 1 Load and system parameters for UL1741 testing

System parameters		
Frequency		60 Hz
Voltage (line to line)		0.48 kV
DG output power		0.1 MW
DG input DC voltage		900 V
Switching frequency		8 kHz
Grid resistance		0.02 Ω
Grid inductance		0.307 mH
DG controller parameters for default case		
Power PI controller	$K_p = 3$	$K_i = 0.08$
Current PI controller	$K_p = 2$	$K_i = 0.01$
Load default parameters		
R, Ω		2.304
L, H		0.00611
$C, \mu F$		1151
Quality factor		1

flow of DG is constant, the instantaneous VPA does not go beyond the nominal VPA in grid mode. Therefore, the output of *abc-to-dqo* transformation block will be constant and it has no considerable adverse effects on the power quality. This is an all-important advantage of this method. In the islanding condition, the instantaneous VPA of inverter (σ) will be altered and amplitude of error (difference) between σ and σ_n will grow then I_d and I_q components will change. Fig. 3 shows the way that we added a new block for the proposed method.

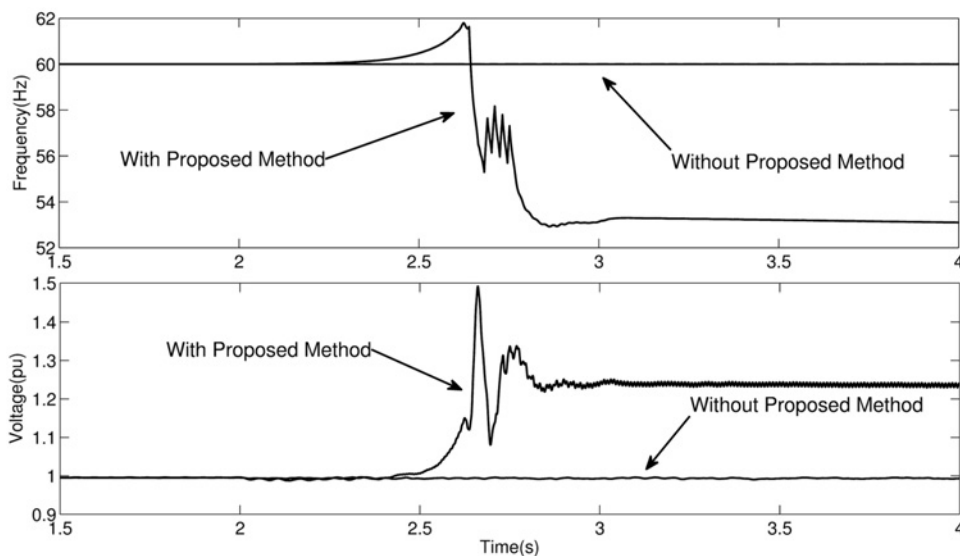

Fig. 4 Islanding detection with proposed method for default cases

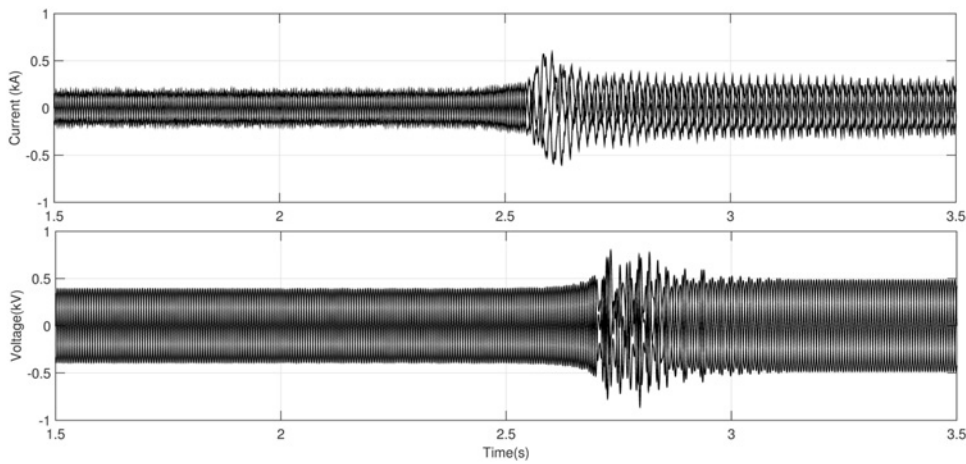

Fig. 5 Waveform of voltage and current

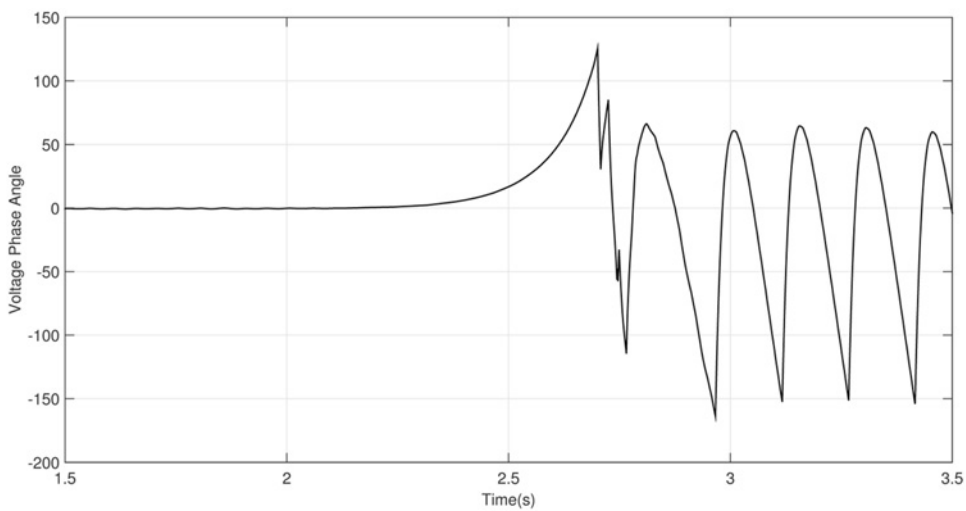

Fig. 6 Amplitude of error between the instantaneous VPA (σ) and the nominal VPA of DG (σ_n)

4 Evaluation of the proposed method by simulation

As mentioned before, the reactive powers of DG are zero because it should operate near the power factor of one. The load is adjusted in such a way that power mismatch between load and DG is minimum; moreover, the resonance frequency of load is near the system frequency because a worst case should be assumed in the islanding detection scenario. A complete list of system parameters is provided in Table 1 [1].

Load parameters in Table 1 are considered as a default case that will be compared with other case studies. For default scenario, the island happens at $t = 2$ s and Fig. 4 shows simulation results for this scenario. As can be seen, the island could be detected within 0.5 s by proposed method; in addition, it is obvious that system and DG cannot detect island without detection method due to small power mismatch. For more clarification, waveform of voltage and current is provided in Fig. 5 to show detection method's performance. In addition, Fig. 6 shows that the changing of error amplitude between the instantaneous VPA (σ) and the nominal VPA of DG (σ_n) start after islanding. In the following sections, different conditions will be tested for evaluation of proposed method performance.

4.1 Load switching scenario for evaluation the proposed method

As previously mentioned, some of active islanding detection techniques probably suffer from load switching's disturbances.

Thus, before testing different load conditions, the simulation results of load switching will be proposed. The load switching may have a significant frequency deviation or voltage variation causing a wrong detection instead of an island detection [32, 33].

Extra load will be added to current local load to simulate load switching for evaluation of proposed method's performance. These tests show the negligible effects of proposed technique on the power system parameter during the load changing. Five cases are proposed for investigation and their parameters are given in Table 2. Extra loads are connected and disconnected to the island area at $t = 2.1$ s and $t = 3.2$ s, respectively, in all the cases. It can clearly be seen in Fig. 7, that there is no considerable changes in the power system parameters. In addition, the variation of active and reactive powers (Fig. 8) show us that proposed method has no considerable effects on the system power quality in comparison with [34, 35].

Table 2 Extra loads parameters

No	kVA	Power factor	
case I	100	1	
case II	80	0.8	lagging
case III	80	0.8	leading
case IV	125	0.8	lagging
case V	125	0.8	leading

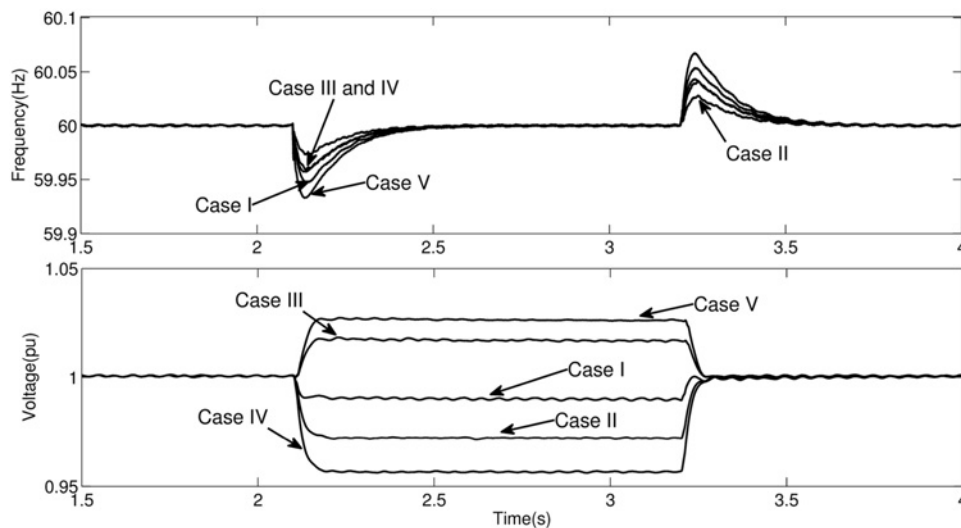

Fig. 7 Frequency and voltage variations during load switching

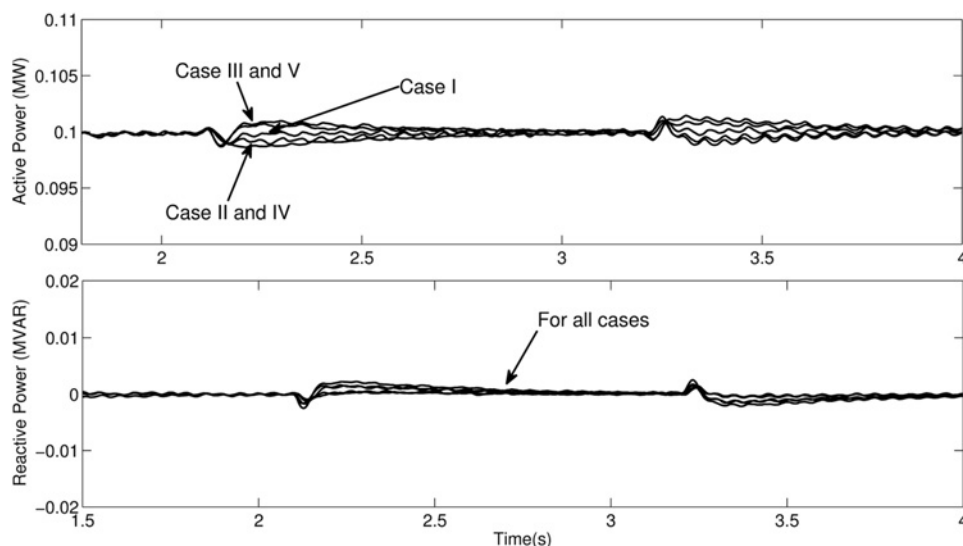

Fig. 8 Active and reactive power variations during load switching

4.2 UL1741 testing

Based on UL1741 Std, active islanding method should be evaluated by different active power mismatch. To create diverse power mismatch scenarios, different ratio of the load active power to the inverter output are created by setting the load active power at 50, 100 and 125% of inverter’s output with complete balanced condition of reactive power. Moreover, changes in reactive load are considered between 95 and 105% of balanced reactive load [1]. For brevity, just two cases will be considered for unbalanced reactive power [36]. In sum, different scenarios of the active and reactive powers under UL1741 testing are shown in Table 3.

Table 3 Load parameters for UL1741 testing

No	L, H	C, μ F	R, Ω	P, %	Q, %
default case	0.00611	1151	2.304	100	100
case 1	0.00611	1151	1.843	125	100
case 2	0.00611	1151	4.605	50	100
case 3	0.00617	1151	2.304	100	99
case 4	0.00605	1151	2.304	100	101

Fig. 9 shows simulation results for cases mentioned in Table 3 and compared with default case. As shown here, the voltage and frequency will change easily in the different power mismatch scenarios at a reasonable time. Furthermore, Fig. 10 shows the results for unbalanced conditions of reactive power (cases 3 and 4) compared with the default case.

4.3 Impact of the load quality factor

RLC loads with higher value of quality factor [5, 18] have a robust tendency to remain at their resonance frequency. The islanding detection method will not properly work if local load has a higher quality factor because load resonance frequency and the system nominal frequency is the same. In fact, a higher value of quality factor may cause a failure in detection methods. Accordingly, the proposed method should be tested for different quality factors.

The rational value of the quality factor is larger than 0.5 and smaller than 2.5 (used in the UK and the USA, respectively) [36]. Fig. 11 shows test scenario for various quality factors between 0.5 and 3. Table 4 shows load parameters for all quality factors. The load resistance is considered such as default case and the test is done with complete balanced condition of the reactive power. It

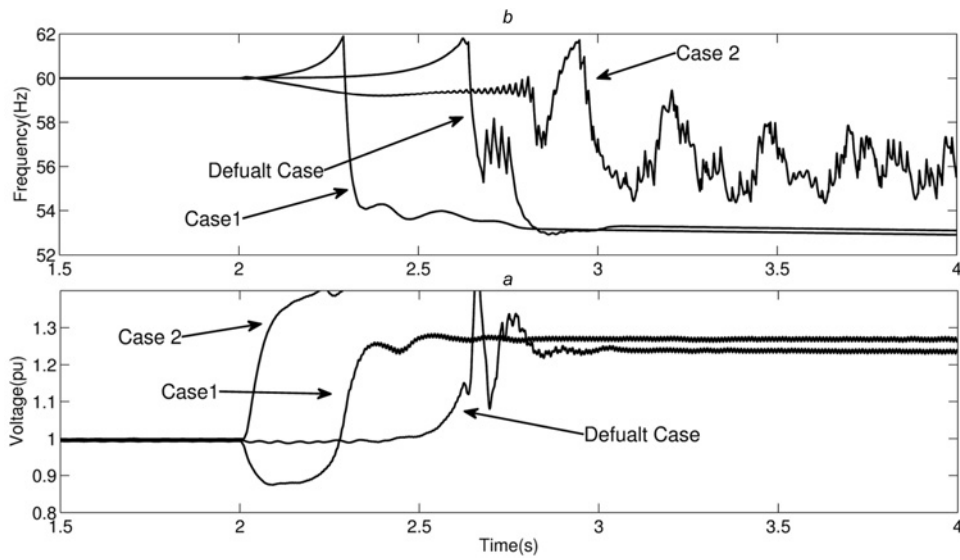

Fig. 9 Frequency and voltage variations for cases 1, 2 and default case

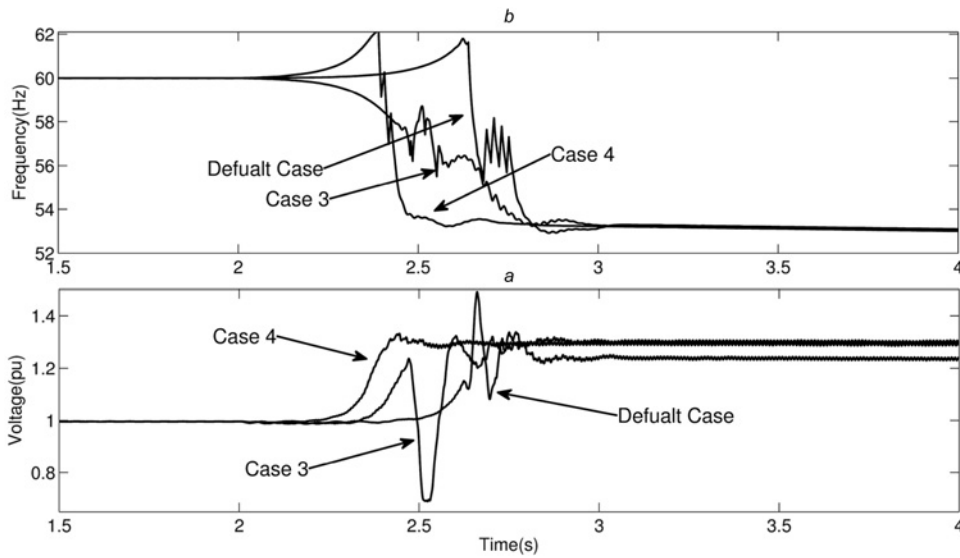

Fig. 10 Frequency and voltage variations of unbalanced conditions of reactive power

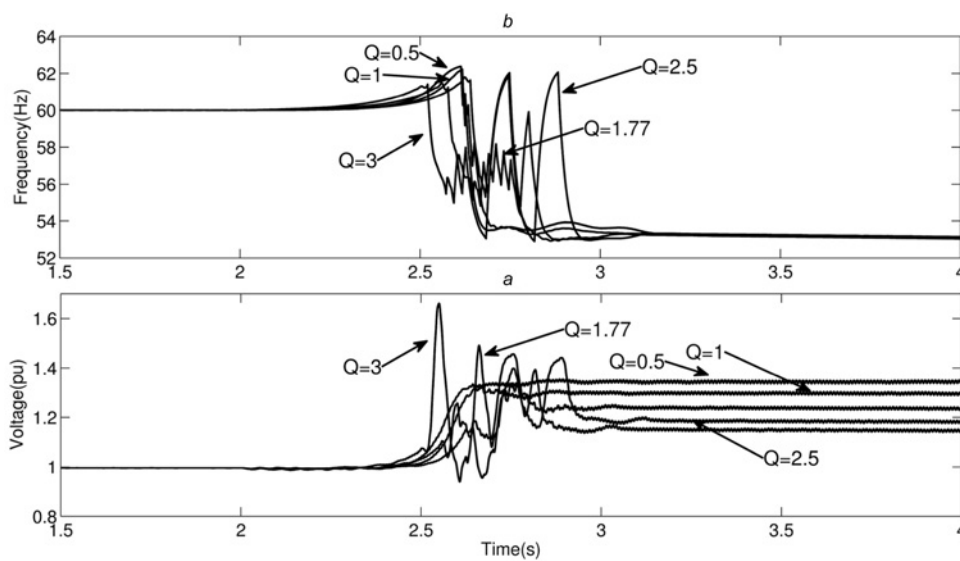

Fig. 11 Islanding detection for different values of quality factors

Table 4 Load parameters for different values of quality factor

Q_f	L, H	$C, \mu F$	R, Ω
0.5	0.01222	575.6	2.304
1	0.00611	1151	2.304
1.77	0.003454	2037	2.304
2.5	0.002445	2887	2.304
3	0.0020387	3454	2.304

Table 5 Output level of DGs

	Case α	Case β	Case γ
DG 1 output, kW	60	50	40
DG 2 output, kW	60	70	80

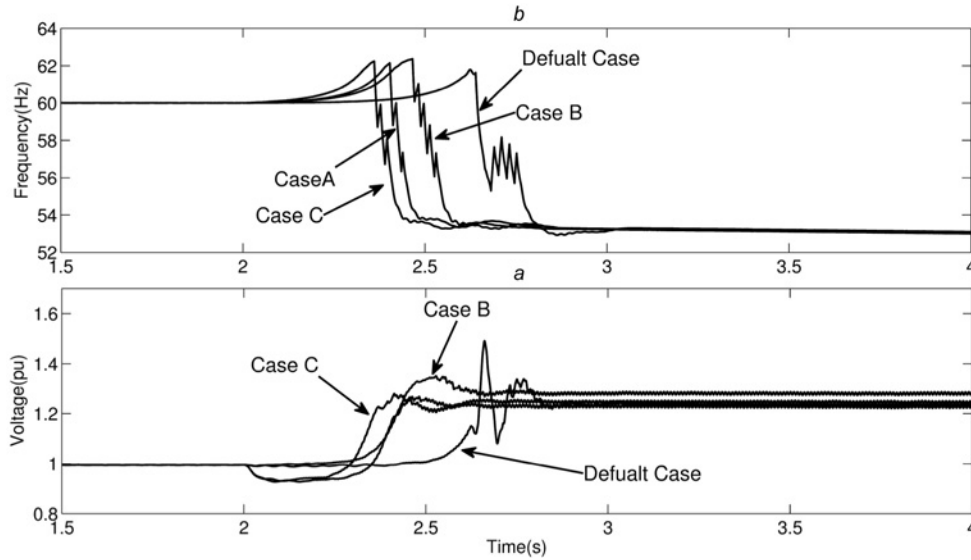

Fig. 12 Frequency and voltage variations for unbalanced load conditions

can clearly be seen; the different quality factors have no negative effect on islanding detection time. Therefore, we can get a result that this method is independent of quality factors.

4.4 Load imbalance effects

According to [21], another test should be done is the study of unbalanced loads' effects on the active and passive detection methods. Three different unbalanced loads are provided by changing of load phase resistance and compared with default case.

Case A: The resistance of phase *A* is set to 95% of its rated value.

Case B: The resistance of phase *B* is set to 110% of its rated value.

Case C: The resistance of phases *A* and *B* is set to 95 and 110% of their rated values, respectively.

Fig. 12 shows that islanding detection time for unbalanced load is shorter than balanced load. Thus, unbalanced load not only does not cause problems for our method, but also help this method have detection time shortened.

4.5 Multiple DGs' effects on the islanding detection

If two or more DGs connect to a same area of power system, detection methods may not detect island area or cause to a false detection when there is no islanding [9, 18]. In addition, DGs

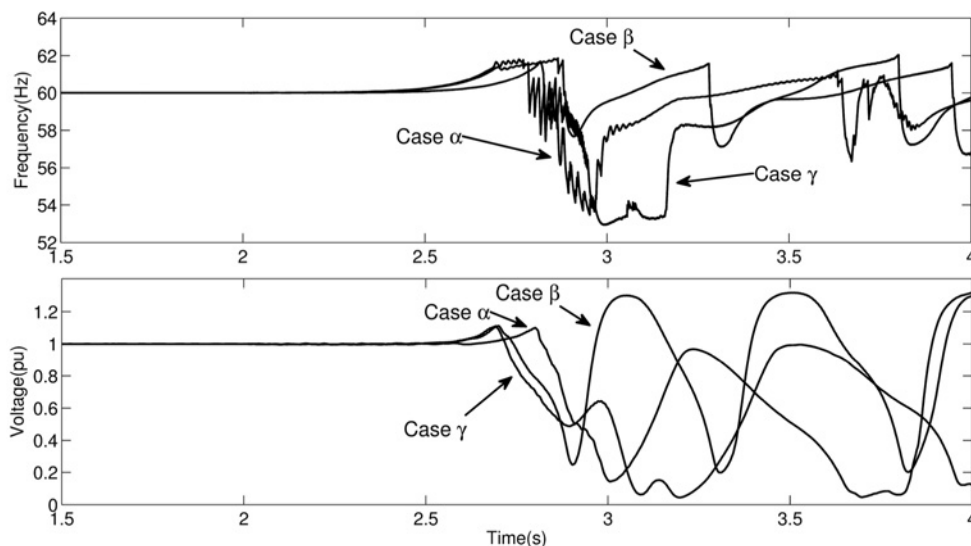

Fig. 13 Frequency and voltage variations after islanding occurrence for multiple DGs with proposed method

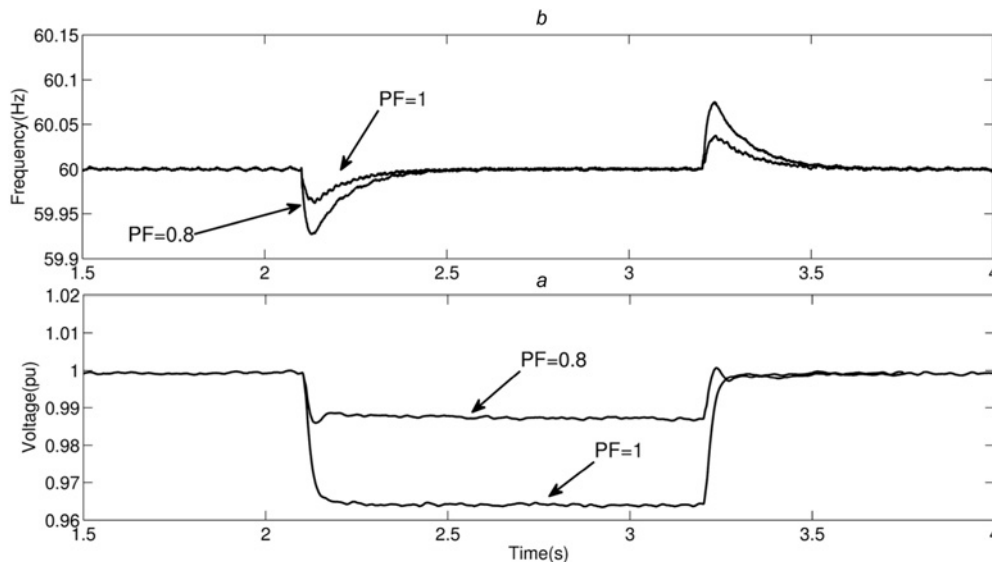

Fig. 14 Frequency and voltage variations during load switching for multiple DGs

interference may affect the power quality, reliability of the system, false tripping, and large non-detection zone. Another similar DG, which uses same detection method, is connected to the PCC for assessment of this method and its effect on several DGs.

The power mismatch between power generation of both DGs and local load of potential islanding area is considered to be small as much as possible. Total load is shared in these different way between two DGs (Table 5). The simulation results of the frequency and voltage are shown in Fig. 13, while island occurs at $t=2$ s. It can easily be seen that there is no significant operation interference between DGs in the normal operation mode.

In this part, load switching is also investigated for multiple DGs because the disturbances of load switching can cause a wrong islanding detection. In two cases, which are considered here, the capacity of DGs is based on the case γ in both of them. In the first case; the load power is 100 kVA with 0.8 power factor and in the second case; the load power is 120 kVA with the unity power factor. Fig. 14 shows simulation results for islanding detection with presence multiple DG. It is clear that there is not any considerable effect on the system parameters during load switching with two DGs.

5 Conclusions

In proposed active detection method, the error between the instantaneous VPA and the nominal VPA will be added to the input angle of abc/dqo transformation block derived from PLL block. In the islanding condition, the VPA will modify; thus, the error amplitude will be increased in the islanding situation causing changes in voltage, frequency and other parameters of system.

To evaluate presented method under different conditions, various tests are provided such as different power mismatch scenarios, unbalanced load, load with different quality factor and effects of multiple DGs. Also, the simulation results show that the load switching has no considerable effects on the power system operation and detection process.

6 References

- IEEE Standard Conformance Test Procedures for Equipment Interconnecting Distributed Resources with Electric Power Systems, IEEE Std 1547.1-2005, 2005, 1–62. doi:10.1109/IEEEESTD.2005.96289
- Chiang, W.-J., Jou, H.-L., Wu, J.-C.: 'Active islanding detection method for inverter-based distribution generation power system', *Int. J. Electr. Power Energy Syst.*, 2012, **42**, pp. 158–166, doi: 10.1016/j.ijepes.2012.03.038
- Dash, P.K., Padhee, M., Panigrahi, T.K.: 'A hybrid time–frequency approach based fuzzy logic system for power island detection in grid connected distributed generation', *Int. J. Electr. Power Energy Syst.*, 2012, **42**, pp. 453–464, doi: http://dx.doi.org/10.1016/j.ijepes.2012.04.003
- Reynen, M.B., Osman, A.H., Malik, O.P.: 'Using gold sequences to improve the performance of correlation based islanding detection', *Electr. Power Syst. Res.*, 2010, **80**, pp. 733–738, doi: http://dx.doi.org/10.1016/j.epr.2009.11.006
- IEEE Recommended Practice for Utility Interface of Photovoltaic (PV) Systems, IEEE Std 929-2000, 2000, doi:10.1109/IEEESTD.2000.91304
- Hashemi, F., Ghadimi, N., Sobhani, B.: 'Islanding detection for inverter-based DG coupled with using an adaptive neuro-fuzzy inference system', *Int. J. Electr. Power Energy Syst.*, 2013, **45**, pp. 443–455, doi: http://dx.doi.org/10.1016/j.ijepes.2012.09.008
- Karegar, H.K., Sobhani, B.: 'Wavelet transform method for islanding detection of wind turbines', *Renew. Energy*, 2012, **38**, pp. 94–106, doi: http://dx.doi.org/10.1016/j.renene.2011.07.002
- Chiang, W.-J., Jou, H.-L., Wu, J.-C., et al.: 'Active islanding detection method for the grid-connected photovoltaic generation system', *Electr. Power Syst. Res.*, 2010, **80**, pp. 372–379, doi: http://dx.doi.org/10.1016/j.epr.2009.09.018
- Bahrani, B., Karimi, H., Irvani, R.: 'Nondetection zone assessment of an active islanding detection method and its experimental evaluation', *IEEE Trans. Power Deliv.*, 2011, **26**, pp. 517–525, doi: 10.1109/TPWRD.2009.2036016
- Kamyab, E., Sadeh, J.: 'Islanding detection method for photovoltaic distributed generation based on voltage drifting', *IET Gener. Transm. Distrib.*, 2013, **7**, pp. 584–592, http://www.digital-library.theiet.org/content/journals/10.1049/iet-gtd.2012.0507
- Chowdhury, S.P., Chowdhury, S., Crossley, P.A.: 'Islanding protection of active distribution networks with renewable distributed generators: A comprehensive survey', *Electr. Power Syst. Res.*, 2009, **79**, pp. 984–992, doi: http://dx.doi.org/10.1016/j.epr.2008.12.012
- Moeini, A., Darabi, A., Rafiei, S.M.R., et al.: 'Intelligent islanding detection of a synchronous distributed generation using governor signal clustering', *Electr. Power Syst. Res.*, 2011, **81**, pp. 608–616, doi: http://dx.doi.org/10.1016/j.epr.2010.10.023
- Ropp, M.E., Begovic, M., Rohatgi, A., et al.: 'Determining the relative effectiveness of islanding detection methods using phase criteria and nondetection zones', *IEEE Trans. Energy Convers.*, 2000, **15**, pp. 290–296, doi: 10.1109/60.875495
- Vieira, J.C.M., Freitas, W., Huang, Z., et al.: 'Formulas for predicting the dynamic performance of ROCOF relays for embedded generation applications', *IEE Proc. Gener. Transm. Distrib.*, 2006, **153**, pp. 399–406, doi: 10.1049/ip-gtd:20045205
- Redfern, M.A., Usta, O., Fielding, G.: 'Protection against loss of utility grid supply for a dispersed storage and generation unit', *IEEE Trans. Power Deliv.*, 1993, **8**, pp. 948–954, doi: 10.1109/61.252622
- Zhao, J.H., Foster, J., Dong, Z.Y., et al.: 'Flexible transmission network planning considering distributed generation impacts', *IEEE Trans. Power Syst.*, 2011, **26**, pp. 1434–1443, doi: 10.1109/TPWRS.2010.2089994
- Najj, W.K.A., Zeineldin, H.H., Alaboudy, A.H.K., et al.: 'A Bayesian passive islanding detection method for inverter-based distributed generation using ESPRIT', *IEEE Trans. Power Deliv.*, 2011, **26**, pp. 2687–2696, doi: 10.1109/TPWRD.2011.2159403
- Pourbabak, H., Kazemi, A.: 'A new technique for islanding detection using voltage phase angle of inverter-based DGs', *Int. J. Electr. Power Energy*, 2014, **57**, pp. 198–205, doi: 10.1016/j.ijepes.2013.12.008

- 19 Yu, B., Matsui, M., Jung, Y., *et al.*: 'Modeling and design of phase shift anti-islanding method using non-detection zone', *Sol. Energy*, 2007, **81**, pp. 1333–1339, doi: <http://dx.doi.org/10.1016/j.solener.2007.06.009>
- 20 Lopes, L.A.C., Huili, S.: 'Performance assessment of active frequency drifting islanding detection methods', *IEEE Trans. Energy Convers.*, 2006, **21**, pp. 171–180, doi: 10.1109/TEC.2005.859981
- 21 Karimi, H., Yazdani, A., Iravani, R.: 'Negative-sequence current injection for fast islanding detection of a distributed resource unit', *IEEE Trans. Power Electron.*, 2008, **23**, pp. 298–307, doi: 10.1109/TPEL.2007.911774
- 22 Jeraputra, C., Enjeti, P.N.: 'Development of a robust anti-islanding algorithm for utility interconnection of distributed fuel cell powered generation', *IEEE Trans. Power Electron.*, 2004, **19**, pp. 1163–1170, doi: 10.1109/TPEL.2004.833439
- 23 Cardenas, A., Agbossou, K.: 'Experimental evaluation of voltage positive feedback based anti-islanding algorithm: multi-inverter case', *IEEE Trans. Energy Convers.*, 2012, **27**, pp. 498–506, doi: 10.1109/TEC.2012.2188529
- 24 Cardenas, A., Agbossou, K., Doumbia, M.L.: 'An active anti-islanding algorithm for inverter based multi-source DER systems'. Asia-Pacific Power Energy Eng. Conf. APPEEC, 2009, doi: 10.1109/APPEEC.2009.4918129
- 25 Cardenas, A., Agbossou, K., Doumbia, M.L.: 'Islanding detection method for multi-inverter distributed generation', *J. Electromagn. Anal. Appl.*, 2009, **01**, pp. 170–180, doi: 10.4236/jemaa.2009.13026
- 26 Aleenejad, M., Mahmoudi, H., Moamaei, P., *et al.*: 'A new fault-tolerant strategy based on a modified selective harmonic technique for three phase multilevel converters', *IEEE Trans. Power Electron.*, 2015, **8993**, pp. 1–1, doi: 10.1109/TPEL.2015.2444661
- 27 Zeineldin, H.H., El-Saadany, E.F., Salama, M.M.A.: 'Impact of DG interface control on islanding detection and nondetection zones', *IEEE Trans. Power Deliv.*, 2006, **21**, pp. 1515–1523, doi: 10.1109/TPWRD.2005.858773
- 28 Bower, W.I., Ropp, M.: 'Evaluation of islanding detection methods for utility-interactive inverters in photovoltaic systems', Albuquerque, NM, and Livermore, CA, 2002, doi: 10.2172/806700
- 29 'UL STD 1741', Inverters, Converters, and Controllers for Use in Independent Power Systems, 2002
- 30 Schauder, C., Mehta, H.: 'Vector analysis and control of advanced static VAR compensators', *IEE Proc. Gener. Transm. Distrib. C*, 1993, **140**, pp. 299–306
- 31 Kim, S.K., Jeon, J.H., Choi, H.K., *et al.*: 'Voltage shift acceleration control for anti-islanding of distributed generation inverters', *IEEE Trans. Power Deliv.*, 2011, **26**, pp. 2223–2234, doi: 10.1109/TPWRD.2011.2132153
- 32 Alaboudy, A.H.K., Zeineldin, H.H.: 'Islanding detection for inverter-based DG coupled with frequency-dependent static loads', *IEEE Trans. Power Deliv.*, 2011, **26**, pp. 1053–1063, doi: 10.1109/TPWRD.2010.2087042
- 33 Menon, V., Nehrir, M.H.: 'A hybrid islanding detection technique using voltage unbalance and frequency set point', *IEEE Trans. Power Syst.*, 2007, **22**, pp. 442–448, doi: 10.1109/TPWRS.2006.887892
- 34 Vahedi, H., Noroozian, R., Jalilvand, A., *et al.*: 'A new method for islanding detection of inverter-based distributed generation using DC-link voltage control', *IEEE Trans. Power Deliv.*, 2011, **26**, pp. 1176–1186
- 35 Zeineldin, H.H.: 'A Q-f droop curve for facilitating islanding detection of inverter-based distributed generation', *IEEE Trans. Power Electron.*, 2009, **24**, pp. 665–673, doi: 10.1109/TPEL.2008.2008649
- 36 Stevens, J., Bonn, R., Ginn, J., *et al.*: 'Development and testing of an approach to anti-islanding in utility-interconnected photovoltaic systems' (Sandia National Laboratories, 2000)