

# Hybrid fuel cell based Distributed Generation system for the Mitigation of voltage sag

M.Keerthivasan<sup>1</sup>, B.Perumal<sup>2</sup>

<sup>1</sup>PG Scholar, Department of EEE, Adhiyamaan College of Engineering, Hosur.  
*krtivsn.er@gmail.com*

<sup>2</sup>Professor, Department of EEE, Adhiyamaan College of Engineering, Hosur.  
*balan\_perumal@yahoo.com*



**Abstract** -This paper concentrates on Hybrid Fuel cell based Distributed Generation system for the mitigation of the balanced and unbalanced voltage sags in the power systems. The proposed system works properly whenever voltage sag occurs in the power system. Current control strategy is developed on the basis of fuzzy controller and the Active power management in the system is based on Neural network controller. This controller decides the super capacitor power that should be generated according to the power available in the DC link. This hybrid system is studied under various balanced and unbalanced voltage sag conditions. Simulation results are given to show the overall performance of the Distributed Generation system.

**Key words** - Control, energy storage, fuel cell (FC), hybrid system, smart grid, voltage sag.

## I. INTRODUCTION

Today, new advances in technology and new directions in electricity regulation encourage a significant increase of distributed generation (DG) resources around the world. The current electricity infrastructure in most countries consists of bulk centrally located power plants connected to highly meshed transmission networks. However, a new trend is developing to-ward distributed energy generation, which means that power conversion systems (PCSs) will be situated close to energy consumers and the few large units will be substituted by many smaller ones. For the consumer, the potential lower cost, higher service reliability, high power quality, increased energy efficiency, and energy independence are all reasons for the increasing interest in what is called "smart grids" PCSs accept any source of fuel (coal, sun, and wind) and transform it into a consumer's end use (heat, light, and warm water) with minimal human intervention. These systems allow society to optimize the use of DG and minimize our collective environmental footprint. Hence, proper control of DG systems is essential in keeping them operational within the power distribution systems to which they are connected. Many of the DG systems, such as fuel cells(FCs), photovoltaic, and wind turbines, are connected to the grid via power electronic converters to improve the system integrity, reliability, and efficiency . Therefore, it is important that the control strategies are designed to keep the system stable under any

disturbance and parameter variations in the distribution system. The grid-connected power electronic converters are highly Sensitive to grid disturbances and it is important to emphasize the necessity to reduce the effects of voltage disturbances on their operation.

In spite of the growing number of DG units, their contribution to the total power delivered to the utility grid remains small, as compared to the power generated by the traditional large power plants. However, they can support the grid in case of disturbances provided that they remain connected, which will be possible only through judicious control strategies such as the ones presented in this paper. Among the wide range of power quality disturbances that severely affect the performance of voltage source converters (VSCs) are voltage sags. A voltage sag is a drop in voltage with duration between one half-cycle and one minute. Operation of DG units under voltage sags has not received much attention in the past, since many grid operators demand the immediate disconnection of DG in case of grid disturbances as prerequisite for grid connection.

However, as the power generated by DG units increases, this behaviour stresses the utility grid and could cause power unbalance, which may turn into instability. Therefore, the interaction between DG units and the grid during voltage sag is very important and it must be considered when designing a proper control strategy. This is the objective of this paper, where a control strategy under voltage sag conditions is proposed for a DG system consisting of a FC combined with energy storage. Up to now, an extensive study has not been introduced for FC DG systems and their operation under voltage disturbances.

The limitations of active power and reactive power injection to the grid during voltage sag should be considered carefully. During voltage sag, a decrease in voltage magnitude affects the grid-connected converter. In this case, the current controllers limit the power that DG unit can supply to the grid to avoid overloading of the converter. For FC DG systems, the power limitation can be a problem resulting in slow dynamics of FC power sources. Hence, to respond to a transient power demand, usually an energy storage device is combined with the FC. The comparison between battery and super capacitor energy storages shows that the use of super capacitor is better than battery for power quality problem studies; also there are some limitations in using a battery. Due to the low power density

of the battery, it can-not release its charge or discharge fast enough during voltage sag.

Additionally, the main drawback of the batteries is a slow response time, limited by a charging current; in contrast, the super capacitor can be acted in a short time, depending on the availability of a high-charging power from the main source. Although the batteries are considered to be the main energy storage devices for DG application, their cycle and calendar life still need to be improved.

In most of today’s DG applications, batteries are used as an auxiliary power source to deliver power for a long time. On the other hand, the use of a super capacitor as an auxiliary source is expected to provide very fast power response and can complement the slower power output of the main source (particularly the FC generator).Therefore, it is important to study the operation and the behaviour of the whole hybrid FC/energy-storage DG system under voltage sag, not just the response of power electronic converters. Hence, in this paper, a robust control strategy has been presented for hybrid FC/energy-storage DG system during voltage sags.

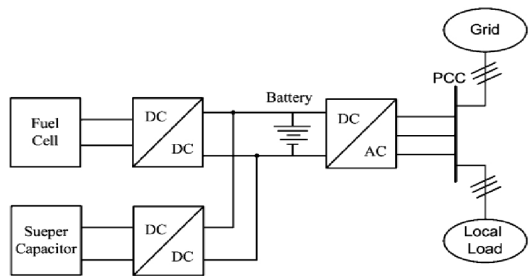

Fig. 1. Hybrid FC/energy storage PCS

II. DESCRIPTION AND MODELING OF POWER GENERATION SYSTEM

The hybrid DG system is based on the centralized dc-bus architecture. In this topology, the FC source and super capacitors are connected to dc bus by boost and buckboostconverters before connecting to the grid as shown in Fig. 1.To boost the lower output voltage of the FC stack to the level of the dc-link voltage as well as to shape the current output of the FC, a boost converter is used. The hybrid dc power source is then connected to the local ac bus by using a voltage source inverter. A Modelling and Control of FC Subsystem FCs are static energy-conversion devices that convert the chemical energy of fuel directly into electrical energy. The model of FC power plant used in this study is based on the dynamic proton exchange membrane FC (PEMFC) stack model developed. The performance of FC is affected by several operating variables, as discussed in the following. This model is based on simulating the relationship between output voltage and partial pressure of hydrogen, oxygen, and water. The Nernst’s equation and

Ohm’s law determine the average voltage magnitude of the FC stack.

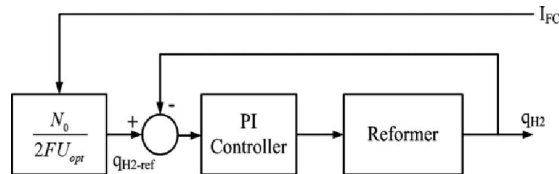

Fig. 2. Reformer controller:

Control of grid-connected VSC is an important problem during voltage disturbances. It needs fast current controllers to track the current references according to change in active and reactive power during the fault. The current controller used in this paper consists of two vector current controllers

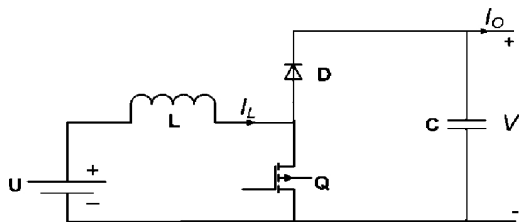

Fig. 3. Boost dc/dc converter model

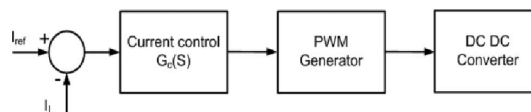

Fig. 4. Block diagram of FC converter control strategy

based on SMC that regulate the positive- and negative-sequence currents separately and are implemented in two different rotating coordinate systems.

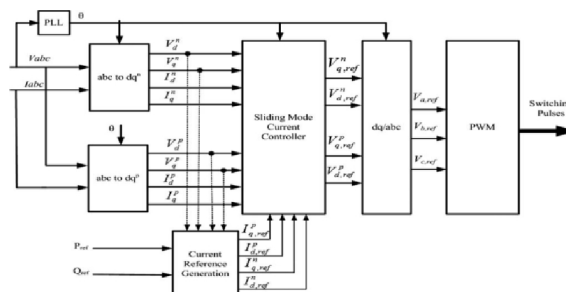

Fig. 5. Block diagram of current control strategy

The positive and negative sequence of dq components is then used along with the reference current signals to produce the reference voltage signals for the PWM regulator. A sequence separation method (SSM) is needed to extract positive and negative sequences [5]. Delayed signal cancellation method (DSC) is probably the best suited SSM, but produces an inaccurate sequences operation during T/4

( $T = 2\pi/\omega$  is the time period) after the beginning of any transient. The layout of this method is illustrated. The abc system is first transformed into stationary  $\alpha\beta$  reference frame using Clark's transformation, and then it is delayed for T/4.

### III. POWER FLOW CONTROL OF HYBRID ENERGY CONVERSION SYSTEM DURING VOLTAGE SAG

In this section, the control strategy of the hybrid FC/energy- storage DG system is presented. The term, "power flow control", refers to the design of the higher level control algorithm that determines the proper power level to be generated, and its distribution between the two power sources. In fact, during voltage sag conditions, the power flow control strategy must be designed to stabilize the dc-link power and regulate the dc-link voltage consequently.

#### A. Voltage Sag Ride-Through Control Strategy

During the voltage sag, a decrease in voltage amplitude occurs at the converter terminal. To keep the power supplied to the grid constant, the current should increase. It will be limited by the current controller, however, to avoid overloading of the converter. This will thus limit the power that the DG unit can supply to the grid during voltage sag, resulting the dc-link voltage increases. To avoid a too high dc-link voltage, the power balance between inverter power and DG power must be satisfied. One existing method to solve these issues is to install energy storages, which absorb power from FC power source. If the losses in both the FC converter and super capacitor converter are neglected, the following differential equation for dc-link is given:

$$\begin{aligned} P_{DG} &= P_{FC} + P_{SC} \\ P_{Load} &= P_{DG} + P_{Grid} \\ Q_{Load} &= Q_{DG} + Q_{Grid} \end{aligned} \quad (1)$$

where:

- $P_{FC}$  FC power;
- $P_{SC}$  super capacitor power;
- $P_{grid}$  grid power.

The following differential equation for dc-link power balance is given:

$$\begin{aligned} C_{dc}v_{dc} \frac{dv_{dc}}{dt} &= P_{FC} + P_{SC} - P_{grid} \\ &= v_{FC}i_{FC} + v_{SC}i_{SC} - P_{grid} \end{aligned} \quad (2)$$

where:

- $P_{FC}$  FC power;
- $P_{SC}$  super capacitor power;
- $P_{grid}$  grid power.

In order to regulate the dc-link voltage, it is necessary to keep the power balance in dc-link. In this equation, the change in grid power is considered as disturbance during the voltage sag. Moreover, to meet the power balance in dc-link, it is important to consider the dynamic limitations of FC power. In this case, the FC power could not change rapidly and the FC controller with dc-dc converter should regulate the operating point of FC. The details of FC and dc-dc converter control strategy are presented in following part. However, the amount of power that should be absorbed by super capacitor to balance the power in dc-link is very important and it depends on the dc-link energy. The dc-link energy measurement is carried out by means of the following calculation:

$$E_{dc}(k) = (1/2)C_{dc}V_{dc}(k) \quad (3)$$

In this paper, a power flow control structure has been developed for hybrid power sources during voltage sag. It is based on fuzzy logic control strategy that determines the super capacitor power according to the following inputs:

$$\begin{aligned} e(k) &= E_{dc-ref}(k) - E_{dc}(k) \\ \Delta e(k) &= e(k) - e(k-1) \end{aligned} \quad (4)$$

where  $E_{dc-ref}$  is the reference dc-link energy that is calculated by reference dc-link voltage. Hence, it is essential to design robust and stable control strategy to guarantee the stability of the dc-link of hybrid system. For this purpose, a Lyapunov-based fuzzy-neural control strategy is developed. In proposed neuro-fuzzy control strategy, for each input, four fuzzy subsets have been used. These are ZE(zero), L(low), M(medium), and H(high). For each of these fuzzy sets, a Gaussian membership function has been used. As each of the two inputs has four subsets, there are altogether control rules in the neuro-fuzzy logic controller.

#### B. Voltage Regulation Capability in Weak Grids

The voltage-regulation capability limit of a converter-interfaced DG is mainly related to the need for the DG to

inject constant active power into the grid. The grid is supplying a load at the far end of the feeder, where a DG is also connected. It is assumed first that the load is disconnected and the DG is supplying both active power  $P_{DG}$  and reactive power  $Q_{DG}$  to the grid. The power flow through the system is described by [8]

$$P_{DG} = V_{PCC}E / |Z_s| \cdot \cos(\theta_z - \delta) - E^2 / |Z_s| \cdot \cos(\theta_z)$$

$Q_{DG} = V_{PCC}E / |Z_s| \cdot \sin(\theta_z - \delta) - E^2 / |Z_s| \cdot \sin(\theta_z)$  (5) where:  $\delta$  angular of grid voltage (E);  $\theta_z$  angular of point of common coupling voltage (VPCC);  $Z_s$  impedance between

DG system and main grid. The DG unit will not always be

able to supply the reactive power that is necessary for compensation, since its converter current is limited. Problems are most likely to occur in low- load/high-generation situations. When the DG unit supplies a large power, there is a chance that the upper voltage limit is exceeded. As the DG unit supplies a large active power, the margin for reactive power consumption is limited or even zero.

According to the proposed analysis, the connection of a DG in a weak distribution system can provide voltage support, if the voltage-regulation capability is added to its controller, in addition to the main function of injecting active power into the grid. For this purpose, a dual-sequence voltage controller is designed to regulate the voltage at the point of common coupling (PCC). The proposed dual-sequence control structure has been shown in Fig. 12. A fuzzy SMC (FSMC) strategy is proposed to design the voltage controller. The SMC perhaps is the best solutions when high performance is required. Moreover, the SMC is well suited for nonlinear dynamic systems with uncertainties. For designing SMC, a discontinuous fast-switching control law forces an infinite gain at the equilibrium point. Subsequently, a wide band of frequency modes are supplied through an equivalent internal model. By this technique, wide range of voltage perturbations can be rejected. The SMC approach is one of the robust control methods to handle systems with mode certainties.

The structure of fuzzy sliding-mode controller is described as follows. Let  $s(x) = 0$  be the sliding surface that is determined by design requirements, and  $x$  is the error state vector. Let  $s$  denote the fuzzy variable of the universe of discourse  $s$ . Then, some linguistic terms can be defined to describe the fuzzy variable  $s$ , such as zero, positive large, or negative smaller, etc. Each linguistic term expresses large” means the system state is far from the sliding surface and  $s(x) > 0$ . Such linguistic expression can be used to form fuzzy control rules as follows:

- R1 : If  $s$  is NB, then  $u$  is PB
- R2 : If  $s$  is NM, then  $u$  is PM
- R3 : If  $s$  is ZO, then  $u$  is ZO
- R4 : If  $s$  is PM, then  $u$  is NM
- R5 : If  $s$  is PB, then  $u$  is NB

Where  $u$  denotes the fuzzy variable of the universe of discourse of the control signal  $u$ , NB denotes “Negative Big,” NM denotes “Negative Mid,” ZO denotes “Zero,” PM denotes “Positive Mid,” and PB denotes “Positive Big”.

#### IV. SIMULATION RESULTS

In order to show the effectiveness of proposed control strategy, the simulation model of the proposed hybrid DG system has been built in MATLAB/ Simulink environment.

The parameters of the hybrid FC/energy-storage DG system is obtained in different Hybrid conditions. Simulation diagrams are shown below.

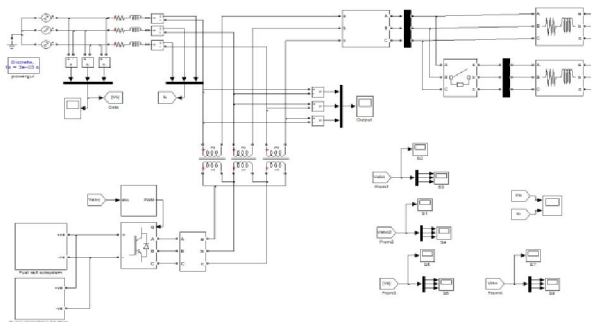

Fig. 6. Simulation diagram of voltage sag mitigation.

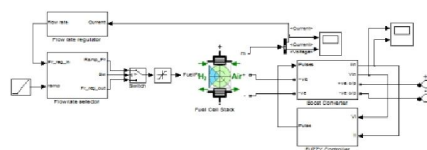

Fig. 7. Fuel cell Sub-system

The above Fig. 7 is the Fuel cell Boost Converter.

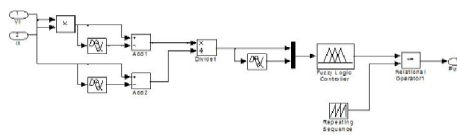

Fig.8. Fuzzy Controller diagram

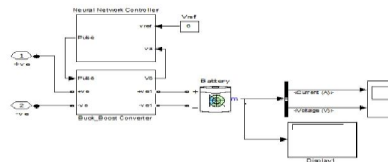

Fig.9. Super-capacitor Buck Boost converter

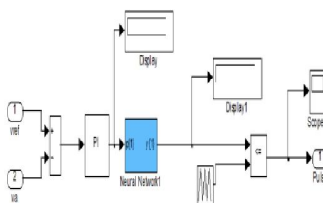

Fig.10. Neural controller for Buck Boost converter.

Simulation results are obtained by MATLAB/ Simulink environment. Simulation diagrams are as follows.

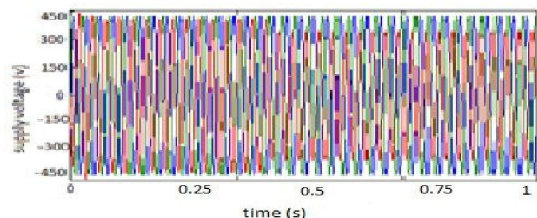

Fig. 11. Supply voltage.

The supply voltage is given from a AC voltage source to the load. At initial condition a part of load is only operated. At the time after 0.3 seconds another part of load is also connected so voltage sag occurs in the power system .

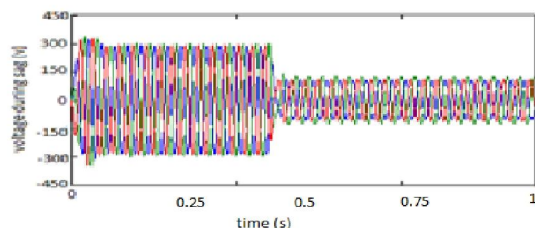

Fig. 12. Voltage during sag period.

The operation of the DG system is shown in the below diagram.

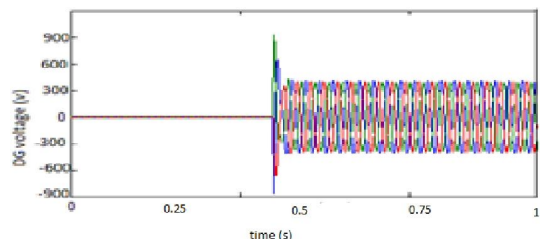

Fig. 13. DG system operating voltage

The regulated voltage is shown in the below diagram which shows that the DG system accurately mitigated the voltage sag from the power system.

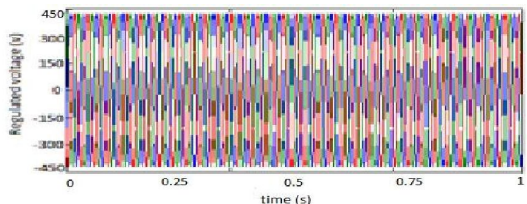

Fig. 14. Regulated voltage

The voltage sag in the power system is fully mitigated using the Hybrid Fuel Cell based Distributed Generation system which is shown in the above Fig. 14. This system could not mitigate all kind of voltage sag with more voltage drop than 85%.

## V. CONCLUSION

This paper presents the hybrid FC based DG system under different operating conditions. For this purpose, complete model of hybrid PCS is presented, and then by designing control strategy for each component, the power control problem of the proposed system is studied under unbalanced voltage sag. Moreover, robust current control strategy has been developed by Fuzzy logic controller and the active power management can be controlled by neural network controller. Simulation results show that the proposed control strategy is able to tolerate under various voltage sags and keep the system performances like active power control. The voltage regulation capability of the proposed control strategy was analyzed as well and it was shown that the extent to which a DG can help the grid to regulate its voltage depends on the DG capacity and the grid capacity.

## REFERENCES

- [1] A. Bayod.R'ujula, "Future development of the electricity systems with distributed generation, energy," J. Energy, vol. 34, no. 3, pp. 377–383, 2009.
- [2] A. Hajizadeh, L. Norum, and M. A. Golkar, "Robust power control of hybrid distributed power generation system during voltage sag," in Proc. IEEE IECON, 2009, pp. 791–797.
- [3] A. Hajizadeh and M. A. Golkar, "Fuzzy neural control of a hybrid fuel cell/battery distributed power generation system," IET Renewable Power Genr, vol. 3, no. 4, pp. 402–414, Dec. 2009
- [4] A. Hajizadeh and M. A. Golkar, "Control of hybrid fuel cell/battery distributed power generation system with voltage sag ride-through capability," in Proc. IEEE PECON, Dec., 2008, pp. 463–467.
- [5] A. Hajizadeh and M. A. Golkar, "Intelligent power management strategy of hybrid distributed generation system," Int. J. Electr. Power Energy Syst., vol. 29, pp. 783–795, 2007.
- [6] B. Wojszczyk, R. Uluski, and F. Katiraei, "The role of distributed generation and energy storage in utilities of the future," in Proc. IEEE PES Gen. Meet pp. 1–2. 2008,
- [7] B. Renders, W. R. Ryckaert, K. De Gussem ´e, K. Stockman, and L. Vandevelde, "Improving the voltage dip immunity of converter-connected distributed generation units," Renewable Energy, vol. 33, pp. 1011–1018, 2008.
- [8] F. A. Magueed, A. Sannino, and J. Svensson, "Transient performance of voltage source converter under unbalanced voltage dips," in Proc. IEEE PESC, Aachen, Germany, 2004, pp. 1163–1168.
- [9] F. Magueed and H. Awad, "Voltage compensation in weak grids using distributed generation with voltage source converter as a front end," in Proc. IEEE PEDS, 2005, pp. 234–239.
- [10]H. Amin Hajizadeh, , Masoud Aliakbar Golkar, and Ali Feliachi, "Voltage Control and Active Power Management of Hybrid Fuel-Cell/Energy-Storage Power Conversion System Under Unbalanced Voltage Sag Conditions" in Proc. IEEE, vol. 25, no. 4, december 2010
- [11] M. H. Bollen, Understanding Power Quality Problems: Voltage Sags and Interruptions. New York: IEEE Press, 1999.